

COIN COLLECTORS
200 SERIES
PREPAY — MAINTENANCE
SINGLE-COIL COIN RELAY

1. GENERAL

1.01 This section covers specific items of maintenance required for prepay coin collectors of the 200 series only. These items cover the single-coil coin relay and coin hopper (Fig. 1) and are in addition to appropriate items covered in the maintenance section on single-coil coin collectors.

1.02 This section is reissued to add information on the new trap-lever spring.

1.03 For information covering the single-coil coin relay used in the 1A1 and 1B1 coin telephone sets, see section on maintenance of single-slot telephone sets.

Caution 1: Remove handset from switchhook before removing or replacing upper housing of coin collector. This reduces the possibility of damage to gate-operating arm.

Caution 2: Tilt the selector card by pressing downward on one of the ears before manually operating the coin relay. This avoids jamming selector card and cam engaging surfaces.

2. TOOLS, GAUGES, AND MATERIAL

2.01 The following tool and gauge are needed in addition to tools, gauges, and material required for general maintenance:

- 146A Gauge — Bias margin test
- KS-14995 Tool — Trap vane release test

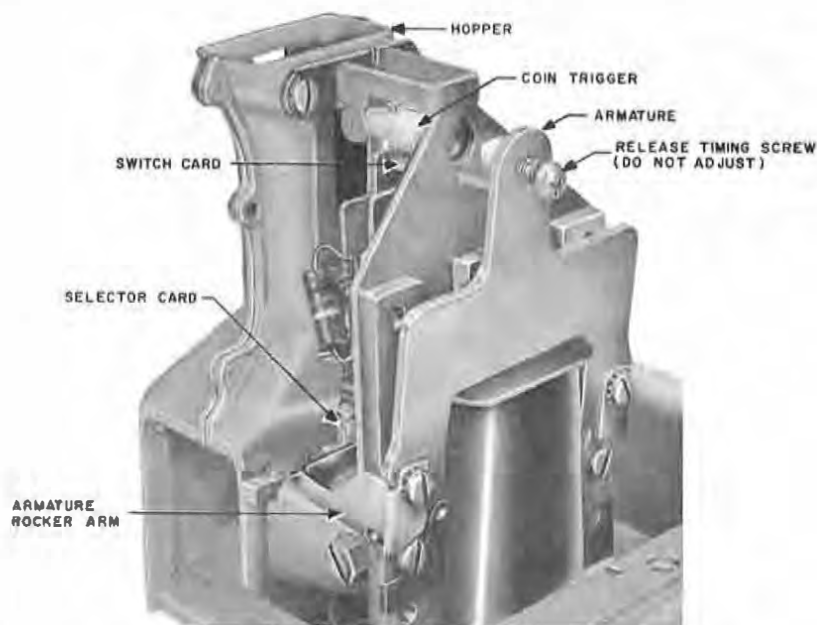
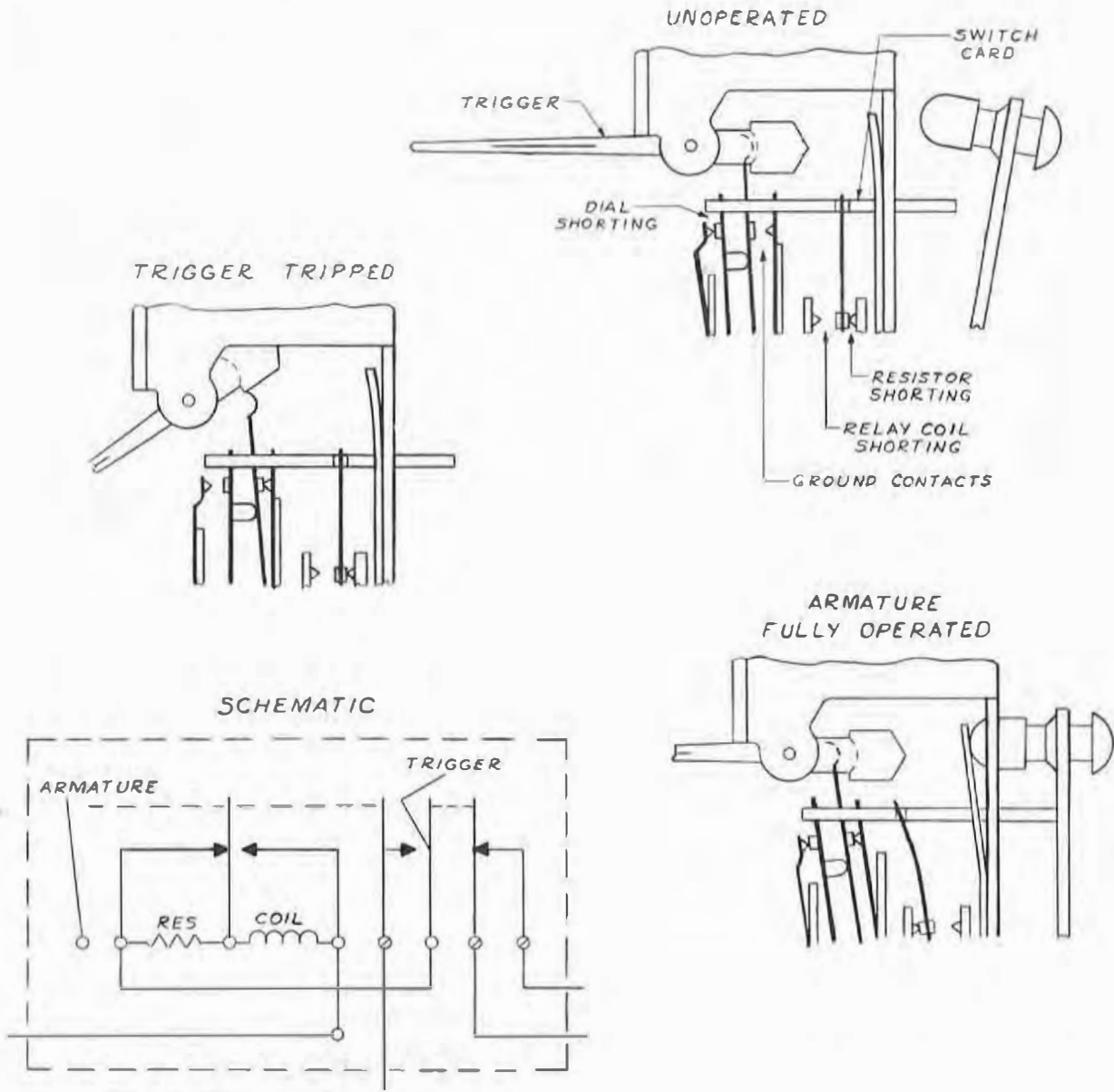

Fig. 1 — P-10E683 Mechanism Unit with P-13E961 Coin Relay

3. COIN RELAY AND HOPPER TESTS

3.01 No modification or adjustment of coin relay or hopper other than those specified herein shall be made. Tests and procedures are as follows and are made with P-10E783 cover removed from coin relay:

Ground contact springs	3.02, 3.03
Dial shorting contact springs	3.04, 3.05
Trap and vane release test	3.06, 3.07, 3.08
Bias margin test	3.09
Cleaning coin relay	3.10
Replacing coin relay	3.11, 3.12
Replacing coin trap and associated parts	3.13 through 3.17
Replacing coin shield	3.18



ON RELEASE AND RETURN TO UNOPERATED POSITION, GROUND CONTACTS OPEN BEFORE RELAY COIL SHORTING CONTACTS OPEN.

Fig. 2 - Contact Spring Assembly

Ground Contact Springs

3.02 Check ground contact springs as follows:

- (1) With trigger tripped, ground contact springs shall make firmly. Check visually and by feel with orange stick. (See Fig. 2.)
- (2) Connect hand test set across line terminals of coin collector and trip trigger. Dial tone shall be heard in dial areas, or operator shall answer in manual areas. If not, proceed as follows:
 - (a) Verify that central office battery and station ground are present on station wiring.
 - (b) If contacts make firmly but test open, burnish contacts with 265C tool.
 - (c) After burnishing contacts, if dial tone is not heard, replace relay.

3.03 An open resistor will result in no coin pilot light at switchboard. To check for continuity through resistor, connect test set across line terminals and, with trigger *not* tripped, close relay armature manually (see Caution 2). Dial tone shall be heard. If dial tone is not heard, resistor is open and relay must be replaced.

Dial Shorting Contact Springs

3.04 With coin trigger unoperated, dial shorting contacts shall be made and shall have perceptible follow. With coin trigger tripped, they shall be open. Check visually.

3.05 Dial shorting contacts shall shunt dial pulsing contacts when coin trigger is unoperated. With ground lead connected, check as follows:

- (1) Provide ground on line by strapping around ground contacts. Insert paper clip or equivalent between ground terminal and spring pile-up portion of No. 4 spring as shown in Fig. 3.

Note: Make sure paper clip does not make with the spring contact portion of No. 4 spring. Avoid making contact with No. 3 terminal.

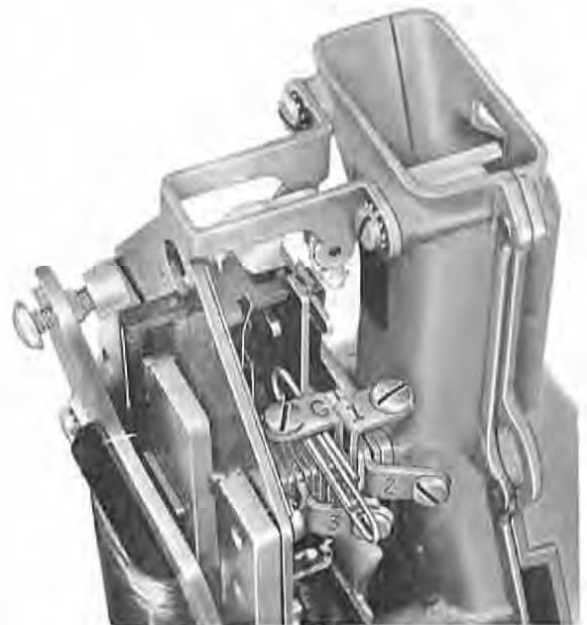

Fig. 3 — Method of Strapping Ground Around Ground Contacts on Coin Relay

- (2) Make sure trigger is *not* tripped.
- (3) Place upper housing on coin collector and wait for dial tone.
- (4) When dial tone is heard, dial any digit except 1. Dial tone should not be broken.
- (5) If dial tone is not broken, remove paper clip and proceed with other tests.
- (6) If dial tone is broken, dial shorting contacts are not shunting dial. Check that dial shorting contacts are made and have perceptible follow with trigger in unoperated position. Burnish contacts with 265C tool. Check housing transfer spring contacts and wiring for continuity.

Trap and Vane Release Test

3.06 Trap, vane, and armature shall restore fully to their nonoperated positions when armature and trap are permitted to restore slowly. Test as follows:

Note: Disconnect ground from coin relay while making this test at manual stations.

- (1) Manually close armature of relay by first pressing downward on selector card ear (left side for collect, right side for refund); then fully close armature by applying pressure near concave area above coil. Armature should make firm contact with center core leg.
- (2) Insert KS-14995 coin collector tool into throat of hopper to operate trap to the limit of its travel. Hold in place as shown in Fig. 4.
- (3) Slowly release armature until further movement is prevented by operated trap.
- (4) Slowly withdraw KS-14995 tool. Take at least 5 seconds.
- (5) Be sure that armature, trap, and vane return to their nonoperated positions and that the trap is locked.
- (6) Make test three times in both the collect and refund directions.

3.07 If mechanism fails to restore properly, check that relay is properly mounted and not binding due to uneven tension on mounting screws. Loosen and retighten mounting screws as covered in 3.12.

3.08 If mechanism still fails, remove coin relay from hopper as covered in 3.11 and proceed as follows:

- (1) Check vane for binding on hopper:
 - (a) Hold vane almost vertical but slightly to the right.
 - (b) Vane shall drop to fully operated refund position (right) when released.
 - (c) Hold vane almost vertical but slightly to the left.
 - (d) Vane shall drop to fully operated collect position (left) when released.
 - (e) If vane binds, replace coin collector.
- (2) Check operation, restoral, and locking of coin trap:
 - (a) Depress trap-lever tab slowly with finger; coin trap shall fall freely and come to a positive stop against front wall of hopper.
 - (b) Release trap lever slowly; coin trap shall restore and lock in its nonoperated position.
 - (c) Replace defective coin trap, trap lever, or pin as required (see 3.15, 3.16, and 3.17).
 - (d) If trap-lever spring is missing or lacks sufficient tension, replace or re-tension spring as required (see 3.15, 3.16, and 3.17).
- (3) Remount coin relay as covered in 3.12 and repeat trap and vane release test. If mechanism fails, replace relay. If replacing relay fails, replace coin collector.



Fig. 4—Trap and Vane Release Test

Bias Margin Test

3.09 The selector card shall assume position for collect or refund operation of the cam against the torque of a 146A gauge. Relay shall operate in the selected direction when appropriate central office coin battery is applied. Test as follows:

Note: Make this test only if coin relay is suspected of failing to operate or of operating in wrong direction.

- (1) To test collect operation, place 146A gauge on right side of selector card as shown in Fig. 5. Make sure wiring does not interfere with movement of gauge.
- (2) Connect hand test set across line terminals.
- (3) Trip coin trigger.
- (4) Obtain collect current by any available local arrangement. Selector card shall cause cam and vane to operate to collect position. Check that operation of vane through hopper throat is correct. If lighting is insufficient, use flashlight beam directed at interior of hopper through return opening on left side, or clean out opening on right side. Trigger shall restore. Make test three times.

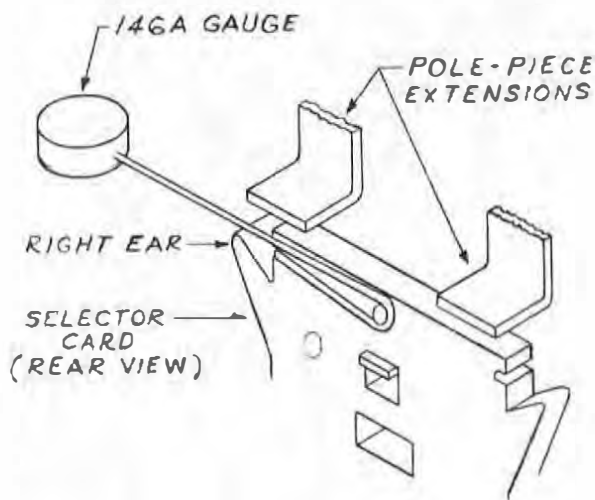

Fig. 5 — Bias Margin Test

- (5) Repeat test in refund direction with 146A gauge on left side of selector card.
- (6) If relay fails to operate fully in the correct direction, remove relay (see 3.11). Remove any foreign magnetic particles which may be lodged between selector card magnet and pole piece extensions (see 3.10).
- (7) Remount relay (see 3.12) and repeat test.
- (8) Replace relay if failure continues.

Cleaning Coin Relay

3.10 If relay has been removed for any reason, remove foreign magnetic particles which may have accumulated on selector card magnet and pole piece extensions. To remove particles:

- (a) Use rubber tape folded over end of orange stick. With armature held closed, press tape against bottom and sides of pole pieces and top of selector card.
- (b) Use new piece of tape for each pole piece.

Replacing Coin Relay

3.11 To remove coin relay from hopper:

- (1) Remove two P-10E810 screw assemblies from top mounting bracket. External tooth lockwasher is captive on these screws.
- (2) Remove two P-10E752 hex-head machine screws which secure relay to hopper arms at each side of relay.
- (3) Slide relay forward to clear trap and vane, and lift upward.

3.12 To replace relay on hopper:

- (1) Move vane to collect position (left).
- (2) With trigger tripped, place relay on hopper arms.
- (3) Slide relay back until trigger enters opening in hopper and trap-lever tab just enters slot in selector card (Fig. 6).
- (4) Close relay armature manually by first pressing downward on ear on left side of selector card. With armature held closed and cam in collect position, slide relay back. Vane stem should enter hole in cam and mounting screws should line up.

Note: Do not attempt to install relay if trigger-support bracket is so distorted that mounting holes do not engage mounting bosses on hopper.

(5) Place and tighten mounting screws evenly. Make sure that trigger has some end play and that armature, trap, and vane operate and release without binding. To check:

- (a) If trigger binds, loosen upper mounting screws. If trigger is free with top mounting screws loose, retighten screws evenly.
- (b) If trigger still binds, replace relay.

Replacing Coin Trap and Associated Parts

3.13 The initial design of the P-10E702 trap-lever spring resulted in occasional disengagement of the spring from the trap lever. This disengagement may cause coins to drop through the coin trap before operation of the coin relay.

3.14 To prevent disengagement, the trap-lever spring has been redesigned. The new spring has three 90-degree angles instead of two. (See Fig. 7.) For field replacement of the trap-lever spring, follow procedures outlined in 3.15 and 3.16.

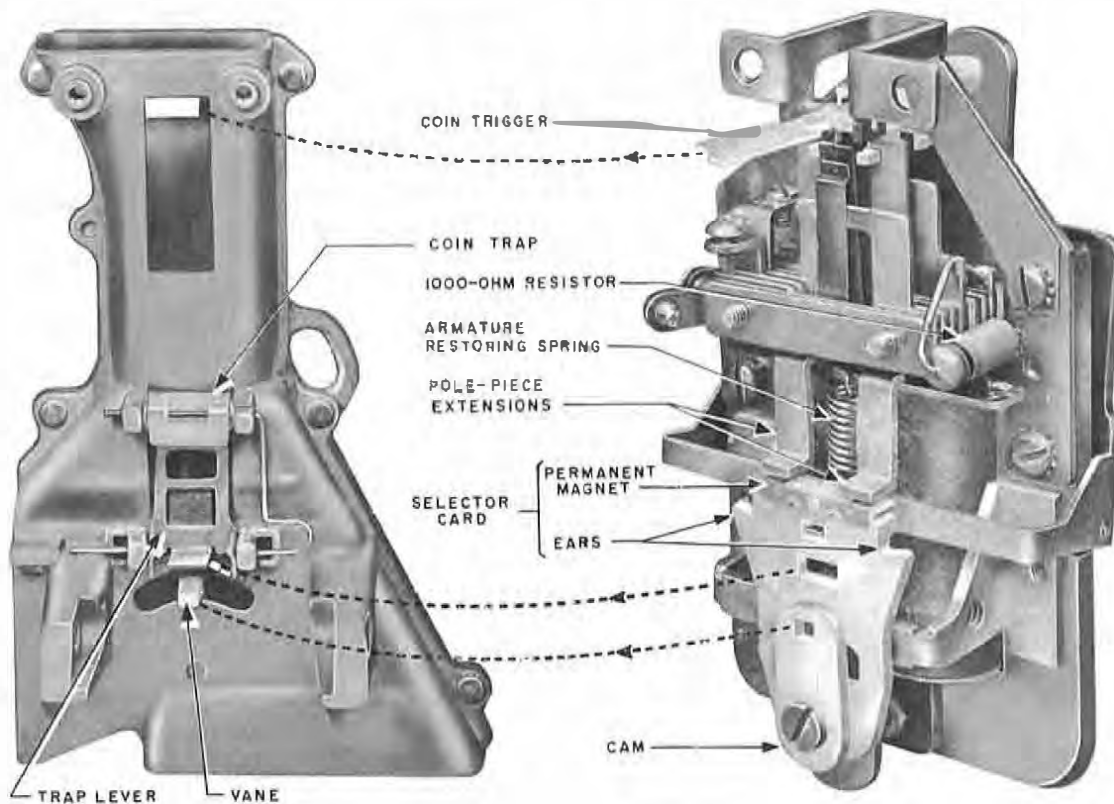

Fig. 6 — Coin Hopper and Rear View of P-10E786 Coin Relay

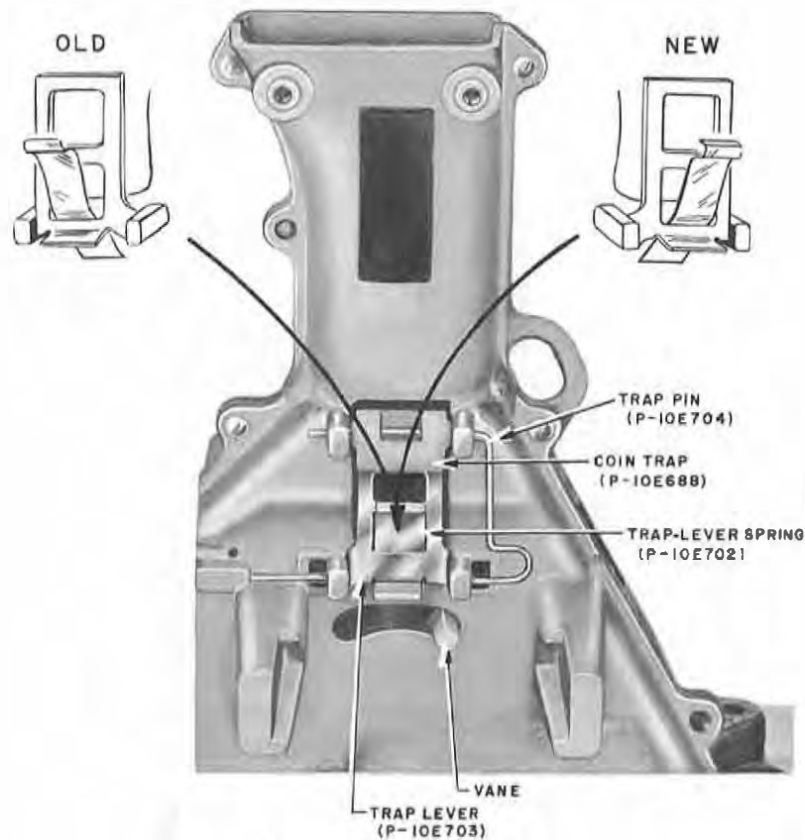

Fig. 7 - Trap-Lever Spring and Trap Lever Assembled

3.15 To remove coin trap, trap lever, and trap-lever spring:

- (1) Remove coin relay from hopper (see 3.11).
- (2) Place vane in refund position (right).
- (3) Block openings in mechanism base to prevent loss of parts.
- (4) Remove trap pin by sliding vertical portion over boss on front of hopper.
- (5) Turn coin trap sideways and remove through opening in front of hopper.

3.16 To replace trap-lever spring:

- (1) Place trap lever and spring on a flat surface (Fig. 8).

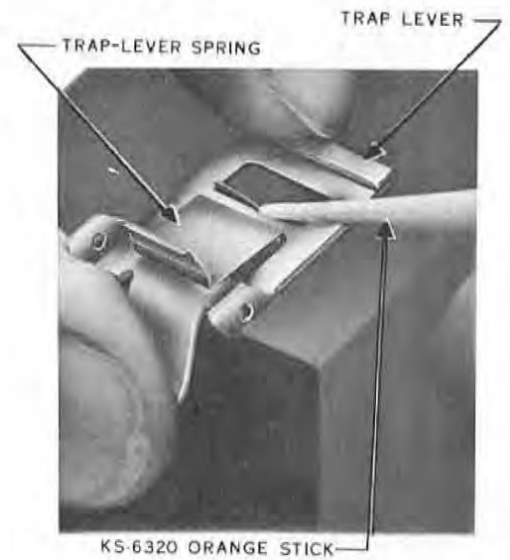

Fig. 8 - Bending Trap-Lever Spring



Fig. 9 - Trap-Lever Spring Assembled on Trap Lever

- (2) Using a KS-6320 orange stick or a fiber spludger, bend trap-lever spring around center bar of trap lever (Fig. 8 and 9).

Caution: Avoid distorting trap-lever spring during bending and insertion operations.

SECTION 506-110-302

3.17 To replace coin trap, trap lever, and trap-lever spring:

- (1) Partially insert trap pin into hole in hopper.
- (2) Insert coin trap in hopper and engage pin in trap (Fig. 10).
- (3) Place trap lever on trap pin (Fig. 11).
- (4) Push pin through holes in coin trap, trap lever, and hopper.

Caution: Be sure that trap-lever spring is between trap pin and hopper as shown in Fig. 12.

- (5) Check operation, restoral, and locking of coin trap as covered in 3.06.
- (6) Replace relay on hopper.

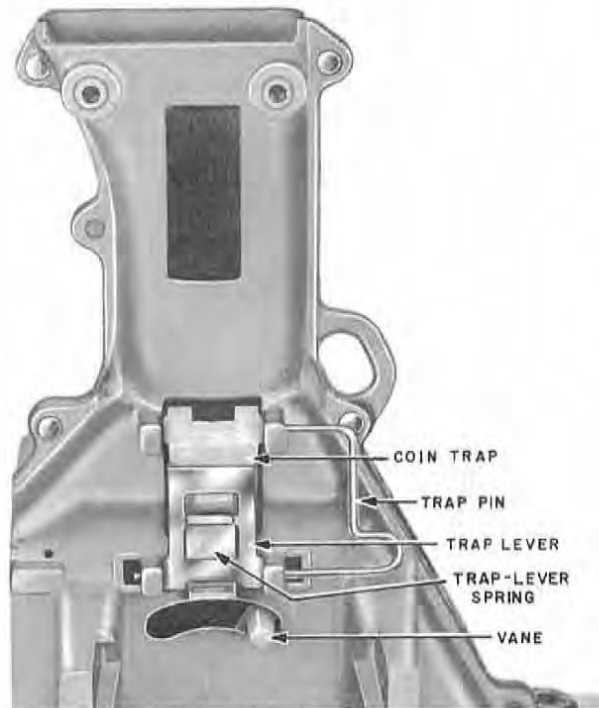

Fig. 11 — Placing Trap-Lever Pin on Hopper

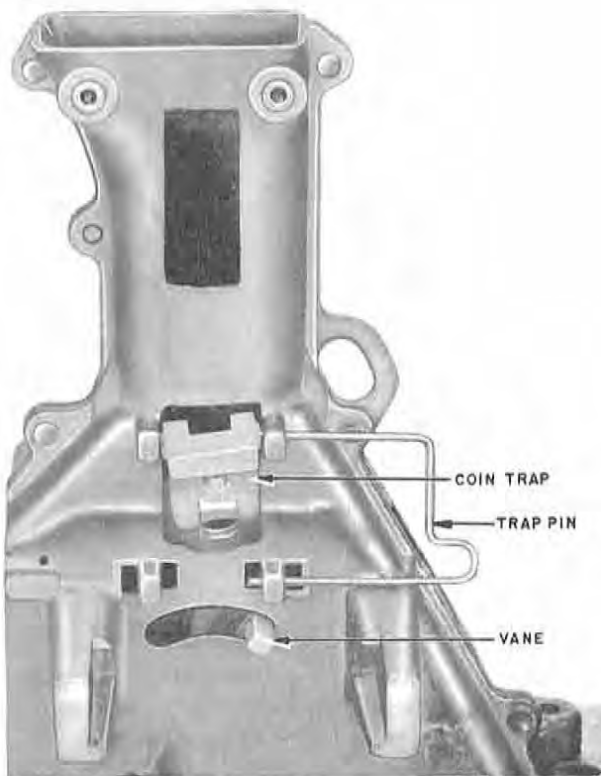

Fig. 10 — Placing Coin Trap on Hopper

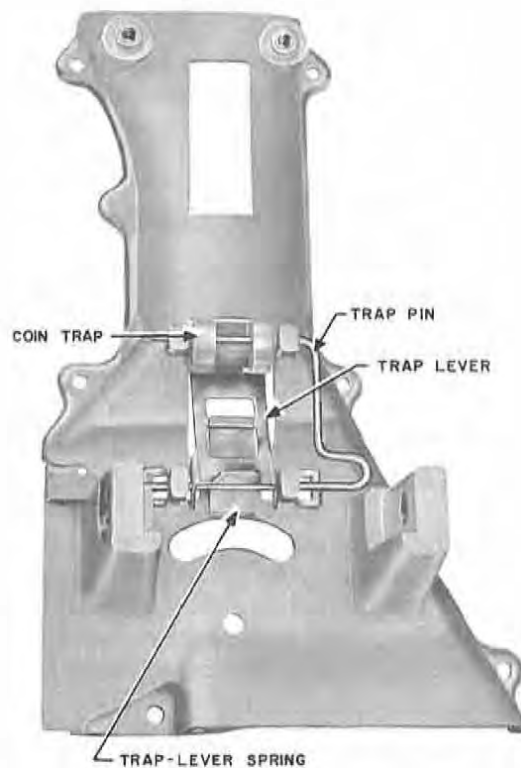

Fig. 12 — Trap-Lever Spring under Trap Pin

Replacing Coin Shield

3.18 If coins stick due to damaged or distorted coin shield, replace shield. If coin shield sticks due to a bent pin, replace pin. Replace shield and pin as follows:

Note: Coin shield is not required on coin collector equipped with pull-bucket return chute.

- (1) Place P-10E705 pin through bearing at top of P-10E706 shield so that curved-in portion on bottom of shield is toward hopper when loop of pin is toward the front (Fig. 13).
- (2) Hold loop of pin with long-nose pliers or fingers and place coin-shield pin in hole in rear of hopper.
- (3) Hold shield in place with fingers. Secure end of loop in front hole of hopper with long-nose pliers.
- (4) Adjust loop so that pin does not come out when play is taken up in either direction.
- (5) Check operation of shield.



Fig. 13 — P-10E706 Coin Shield

4. FINAL TESTS

Coin Chute Operation and Refund Test

4.01 Ensure that coin chute and coin return paths are clear and that station and coin relay are operating satisfactorily. Make final test as follows:

- (1) Place P-10E783 cover on coin relay.
- (2) With upper housing locked in place and with handset *off switchhook*, deposit nickel. Nickel shall be held at holding latch. Lower switchhook slowly; coin shall drop into coin return. Make test five times.
- (3) If coin collector is equipped with washer-reject and coin-release mechanism, test as follows:
 - (a) With handset *off switchhook*, deposit nickel. Nickel shall be held at holding latch. Operate pushbutton slowly; nickel shall be released by gate and drop into coin return. Make test five times.
- (4) With handset *off switchhook*, deposit nickel. Nickel shall be held at holding latch. Deposit second nickel. Second nickel shall release first nickel and permit both coins to pass through coin chute, strike gong, and trip trigger as they drop into hopper. Dial tone shall be heard at dial stations, or operator shall answer at manual stations. Deposit a third nickel. Third nickel shall pass through coin chute (observed by gong tone) and reach trap in coin hopper.
- (5) At dial stations, when dial tone is heard, dial any digit except 1 to break dial tone; then hang up handset. Coins shall drop into coin return on hangup. At manual stations, request that coins be returned when operator answers.
- (6) With handset *on switchhook*, deposit dime. Dime shall pass through coin chute, strike gong twice, and trip trigger. Dial tone or manual operator shall be heard after handset is removed from switchhook.

- (7) With handset *off switchhook*, deposit dime. Dime shall pass through coin chute, strike gong twice, and trip trigger. Dial tone or manual operator should then be heard.
- (8) With handset *on switchhook*, deposit quarter. Quarter shall be stopped by the open gate. Remove handset from switchhook. Gate will be closed, and quarter will be released and strike gong. Dial tone or manual operator shall be heard.
- (9) With handset *off switchhook*, deposit quarter. Quarter shall pass through coin chute, strike gong, and trip trigger, bringing in dial tone or manual operator.
- (10) If cutover clip is used for 5-cent operation, initial nickel deposited shall not be held at holding latch. All other tests shall be the same as above (see Fig. 14).

Coin Signal Test

4.02 Notify operator that tests for coin signals are about to be made and that coins are to be returned after deposit. Deposit nickel, dime, and quarter. If operator does not identify signals correctly, inspect station for trouble. Correct as specified under coin chute alignment in the section on maintenance of coin collectors.

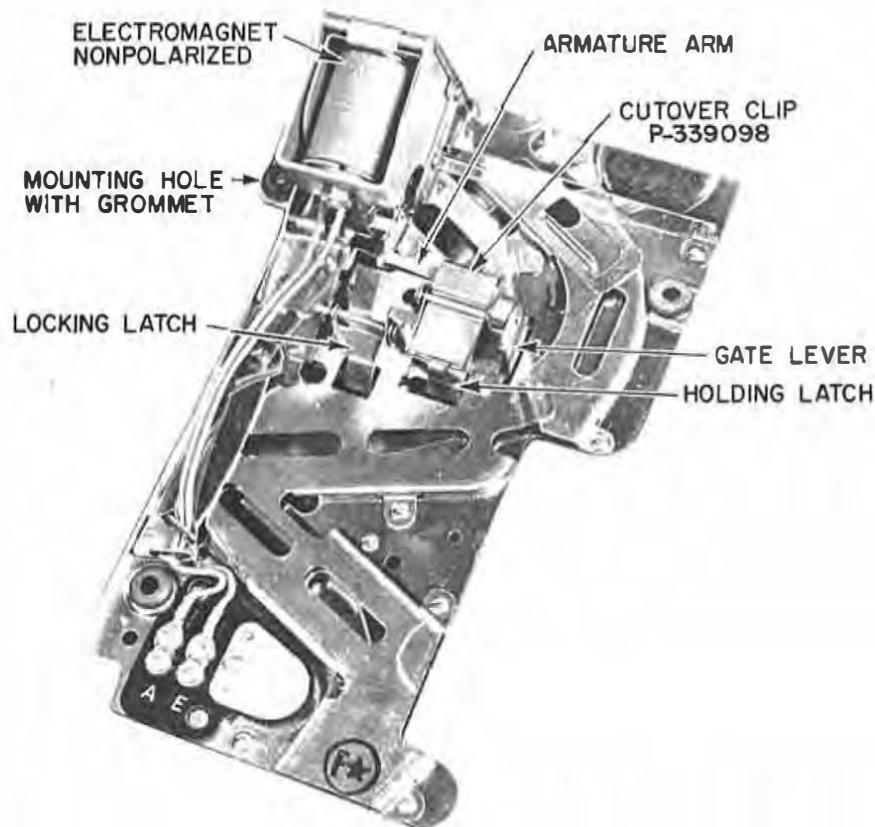

Fig. 14 — Prepay Steel Coin Chute (Equipped with Cutover Clip for 5-cent Service)