

## COIN COLLECTORS

### IDENTIFICATION AND ASSEMBLY OF PARTS

#### 1. GENERAL

1.01 This section identifies coin collectors and gives general information on assembly of equipment. Identifying code numbers and letters are explained and shown in table form.

1.02 This section is reissued to add information on the G3R and F1L hand sets.

1.03 The coin collector consists of a steel lower housing mounted on a cast iron or aluminum backplate, and a steel upper housing which locks in place on backplate and lower housing. The lower housing includes a cash compartment equipped with a steel door, lock, and coin return chute.

1.04 Component parts are assembled on the backplate and lower housing, and either on or in the upper housing. Circuit connections between removable upper housing and backplate are made with spur type contacts on upper housing and contact springs on the backplate.

1.05 All 50-type coin collectors have followed the same basic design. However, they lend themselves to modification, conversion, and interchange of parts to meet changing requirements. The result is the variety of types currently in use. (See Fig. 1.)

#### 2. ASSEMBLY OF PARTS

2.01 Components associated with each type coin collector are listed in the appropriate connection section.



Fig. 1 — Various Types of Coin Collectors

**Types of Wiring**

**2.02** Early coin collectors use a wood terminal strip for station wiring with separately mounted switchhook and transfer spring assemblies (Fig. 2). Later designs use a combined switchhook and transfer spring assembly. (See Fig. 3 and 4.)

**2.03** The antisidetone induction coil and related capacitor of the talking circuit are mounted on the backplate for 180- and 190- series coin collectors (See Fig. 3). All network type and earlier induction coil types use an externally mounted subscriber set for both talking and ringing features. The ringing bridge is provided by a separately mounted subscriber set.

**Cording**

**2.04** Arrange cording so that it will not interfere with gongs, coin channels, or any moving part. Spade tip or wire connections should not

touch any framework or termination point other than the one intended. Examples of cord clamps and wire guides, clamps, and holders are shown in several figures in this section. Handset cords are secured by P-12A096 clamps or P-26E084 set screw. (See Fig. 3 and 4.) Previously, they were anchored by stay loops, hooks, or cords.

**3. ARMORED CORDS**

**3.01** The G1G and F1K hand sets (MD), equipped with neoprene-jacketed armored cords, are replaced with the G3R and F1L hand sets respectively.

**3.02** The G3R and F1L hand sets are equipped with a PVC-jacketed cord with an outer covering of stainless-steel flexible hose.

**3.03** The transmitter and receiver caps are cemented to the handset handle. Since the handset components are sealed, field maintenance is restricted to replacement.

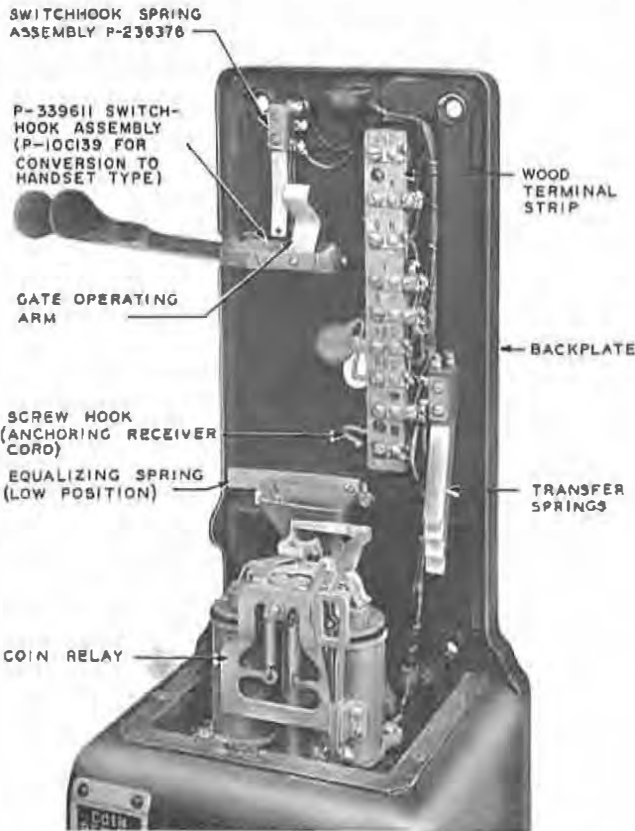

**Fig. 2—Earlier Type Coin Collector with Wood Terminal Strip**

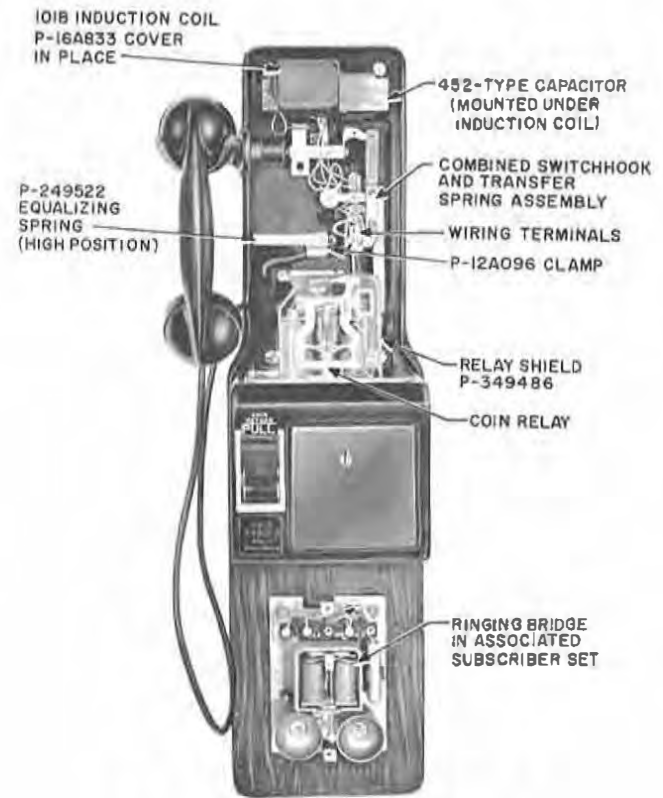

**Fig. 3—Combined Assembly with Induction Coil and Capacitor**

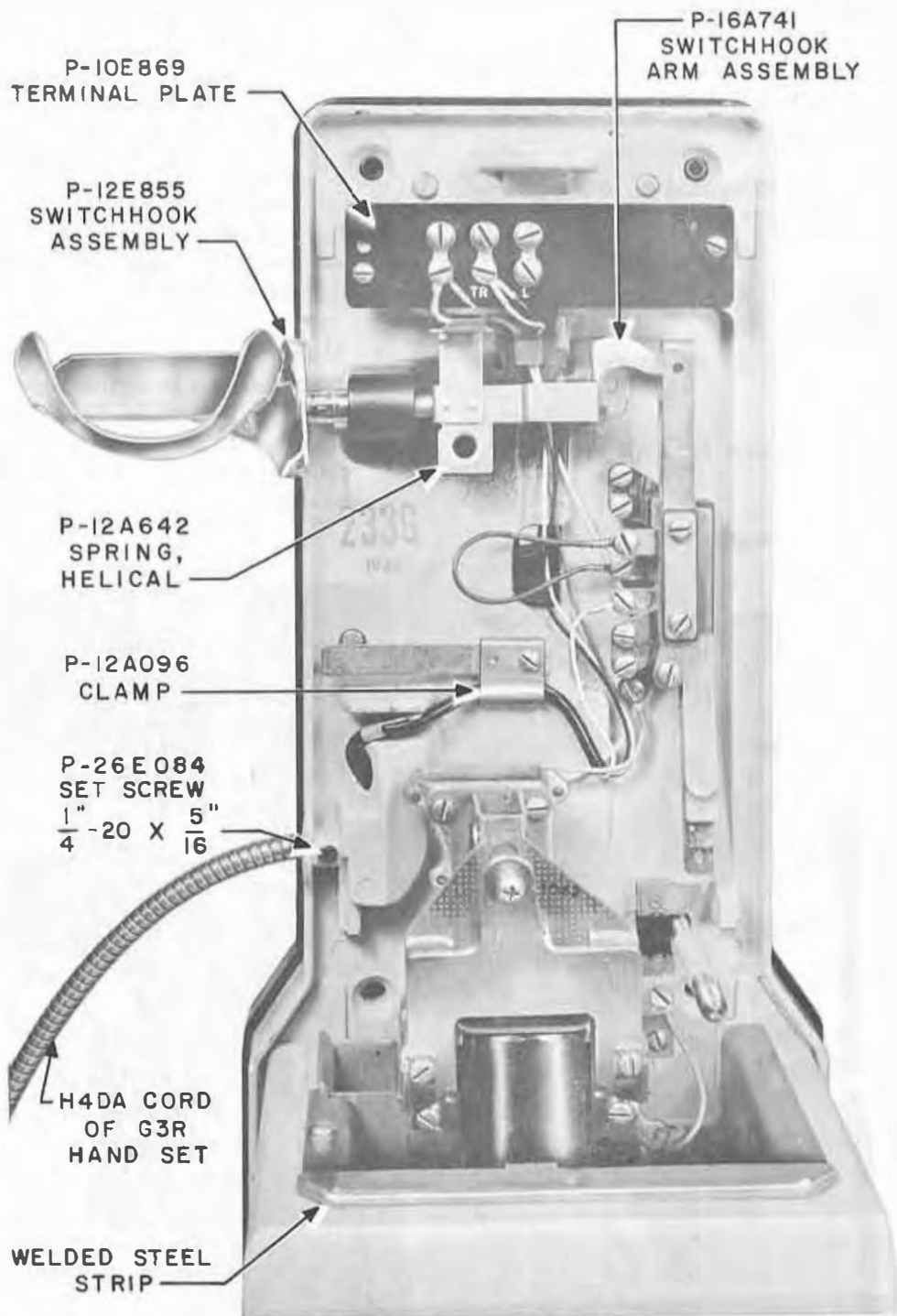

Fig. 4—Typical Backplate Assembly

## SECTION 506-110-101

**3.04** The G3R and F1L hand sets are for use on all coin collectors to give additional handset protection against vandalism.

**3.05** The G3R hand set is available in color. The F1L hand set is available in black only. (See Table E.)

**3.06** All new coin collectors and all 200-type re-issued coin collectors are equipped with the G3R hand set (Fig. 5).

### 4. REPLACEMENT

**4.01** To equip existing coin collectors with G3R or F1L hand sets:

- (1) Obtain proper handset for type coin collector to be modified.
- (2) Remove upper housing.



**Fig. 5 — 233-Type Coin Collector Equipped with G3R Hand Set**

- (3) Disconnect handset cord conductors and cord fasteners. Before removing old cord from cord entrance hole, it is recommended that a pull wire or equivalent be attached to old cord as it is being removed. This aids in pulling in new cord.



*Cover coin relay, hopper, and return chute with plastic, cloth, or other suitable material to prevent metal drill shavings from falling into these mechanisms.*

- (4) Using a small center punch and hammer, mark hole to be drilled and tapped in coin collector backplate. Locate hole in cord entrance tube halfway between outer beveled edge of coin collector and left edge of cord chamber (Fig. 6).



**Fig. 6 — Location of Hole for Socket Set Screw**

- (5) Drill hole with a No. 7 drill (Fig. 6 and step 4).



*When drilling aluminum backplates, do not exert too much pressure on drill. This may cause drill to cut too fast and make hole oversize.*

- (6) Tap hole drilled (step 5) using a  $\frac{1}{4}$ -inch 20 tap with a Greenfield T-Handle tap wrench or approved equivalent.

*Caution: The tap wrench should be long enough to permit wrench handle to protrude out and beyond the coin relay. This prevents injury to craftsman's hands on the coin relay or possible damage to relay.*

- (7) Clean metal shavings from cord entrance hole.

- (8) Pull in new cord using pull-in wire (step 3).

- (9) Remove pull-in wire from new cord and fasten a P-12A096 clamp over cord (Fig. 7).

- (10) Use a P-26E084 ( $\frac{1}{4}$ -20 x  $\frac{5}{16}$ -inch) self-locking set screw to secure cord to coin collector backplate (Fig. 7). A flat surface is located approximately  $\frac{1}{4}$  inch from the set end of the stainless-steel flexible hose. Using a  $\frac{1}{8}$ -inch Allen wrench, screw the socket set screw into hole drilled (step 5) until it just makes contact with flat surface of metal hose. Give set screw one full turn. This should hold cord firmly in coin collector.

*Caution: Screwing the socket set screw down more than one turn against the steel flexible hose may damage cord conductors.*



**Fig. 7 — Cord of G3R Hand Set  
Fastened to Coin Collector Backplate**

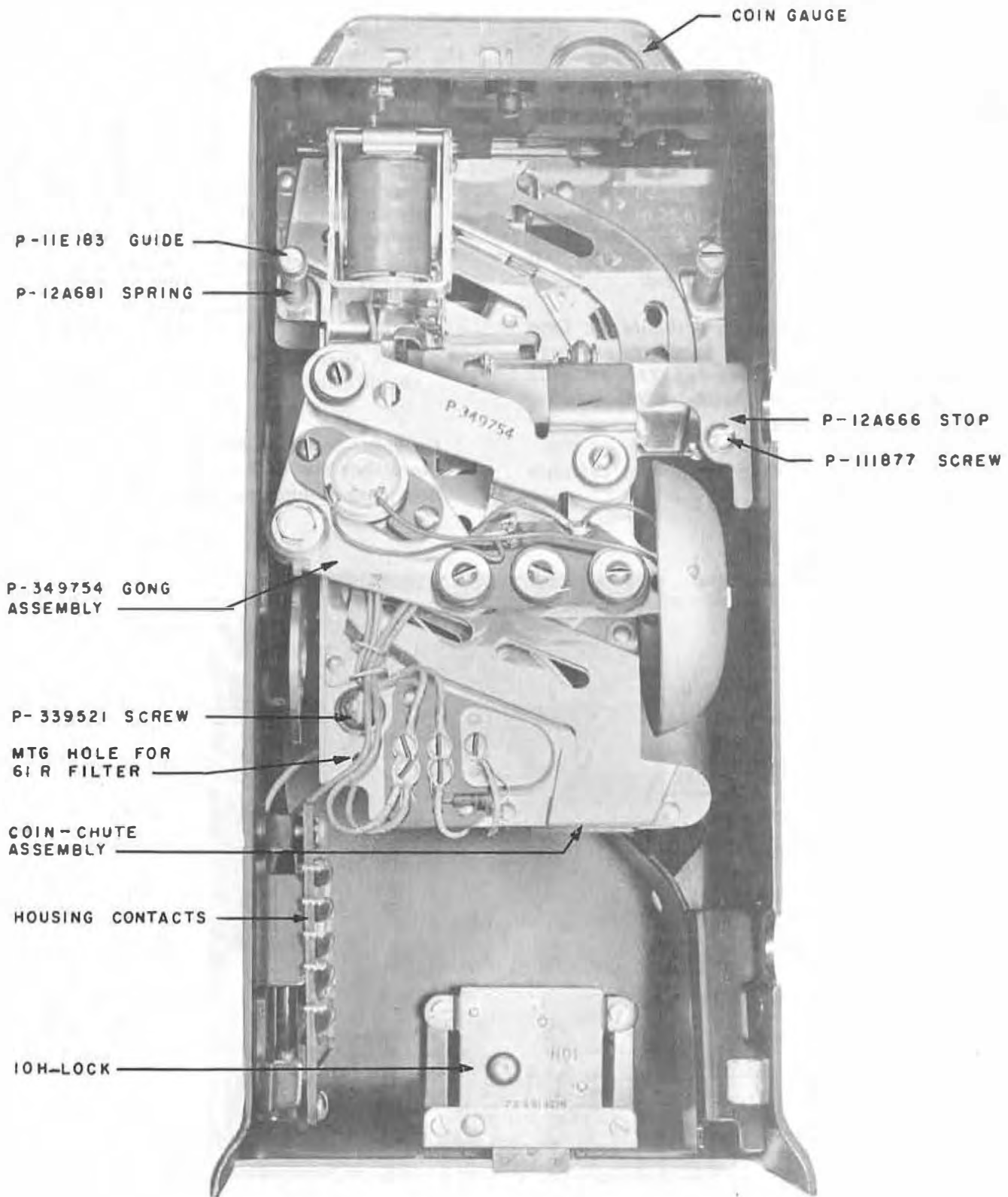

Fig. 8 - Upper Housing, Rear View



- (11) Connect cord conductors, remove protective covering (step 3), and replace upper housing.

**Caution:** *Brush out all metal shavings from coin collector, booth shelf, and booth. Dispose of shavings where they will not cause injury to public or damage to equipment.*

## 5. UPPER HOUSING

**5.01** The coin gauge is riveted to the upper housing and is not replaceable in the field (Fig. 8). When provided, the washer rejector and associated coin-release pushbutton mechanism are also riveted or permanently attached to the upper housing and are an integral part of the assembly. (See Fig. 9.)

### Dial and Adapter

**5.02** All new coin collectors are equipped with 6-type dials. Shop reissued coin collectors are equipped with 6-type dials when so specified by telephone company. The assembly of a 6-type dial is shown in Fig. 10. The 63A adapter incorporates a coin deflector feature to prevent dropped coins from lodging behind dial.

**5.03** The 6-type dial (Fig. 10) may be used to replace 5-type dials if consistent with zoning practices. The apparatus and parts associated with a 5-type dial are not interchangeable with those used with a 6-type dial. A P-14A544 coin deflector may be used with the 5-type dial and its associated 56A dial adapter (Fig. 11). This deflector cannot be used on coin collectors equipped with washer reject mechanisms. The 5-type dial and 56A dial adapter are mounted in the dial cup with three P-24020 screws.

**5.04** Replacement of dials and associated equipment is covered in the section on general maintenance of coin collectors.

### Apparatus Blank

**5.05** The 50-type apparatus blank covers the dial cup on manual coin collectors (Fig. 1). Two P-222882 RH machine screws hold the apparatus blank in place when used as an instruction card holder on dial coin collectors (Fig. 12).

**5.06** The chrome-plated 50K-44 apparatus blank replaces the 50L and 50K-3, -51, and -60 apparatus blanks.

**5.07** The 8-type cardholders mount on top of housing behind coin gauge (Fig. 12). Three P-243217 RH slotless machine screws, P-92383 hex nuts, and P-423631 lockwashers hold card holder in place. The 8B-44 cardholder is chrome plated. It replaces the 8C, 8B-3, -51, and -60 cardholders and it may be used on all color collectors.

**5.08** Postpay coin collectors without coin-release pushbutton mechanisms may be equipped with a KS8487, List 1 or List 2 coin gauge guard (Fig. 13 and 14). Coin gauge guards are designed to attract attention of customer to read instructions before depositing coins. The device consists of a mounting bracket and a transparent hinged guard with the word READ and a pointing red arrow. Raise hinged guard before depositing coins.

### Coin Chute Assembly

**5.09** Coin chutes or coin chute assemblies are mounted inside upper housing. Assemblies associated with the washer reject feature use two P-11E183 guides, two P-12A681 restoring springs, and one P-339521 screw. (See Fig. 8.) Older collectors use two P-12A680 screws instead of guides. Coin chutes not associated with washer reject mechanisms are mounted with three P-339521 screws.

**5.10** Coin chutes and coin chute assemblies are shown in Tables B, C, and D according to types of service, coin features, and equipment.

**5.11** Coin collectors using coin chute assemblies equipped with a P-349754 gong assembly have the 452-type capacitor associated with an electromagnet. It mounts on upper housing underneath the coin chute with a P-347181 clip. (See Fig. 9.)

**5.12** Coin chute assemblies without a P-349754 gong assembly are used on coin collectors with gongs mounted on sides or on a swing type bracket. Coin chute assemblies equipped with a 452B capacitor are used only in upper housings, the gongs mounted on sides of housings.

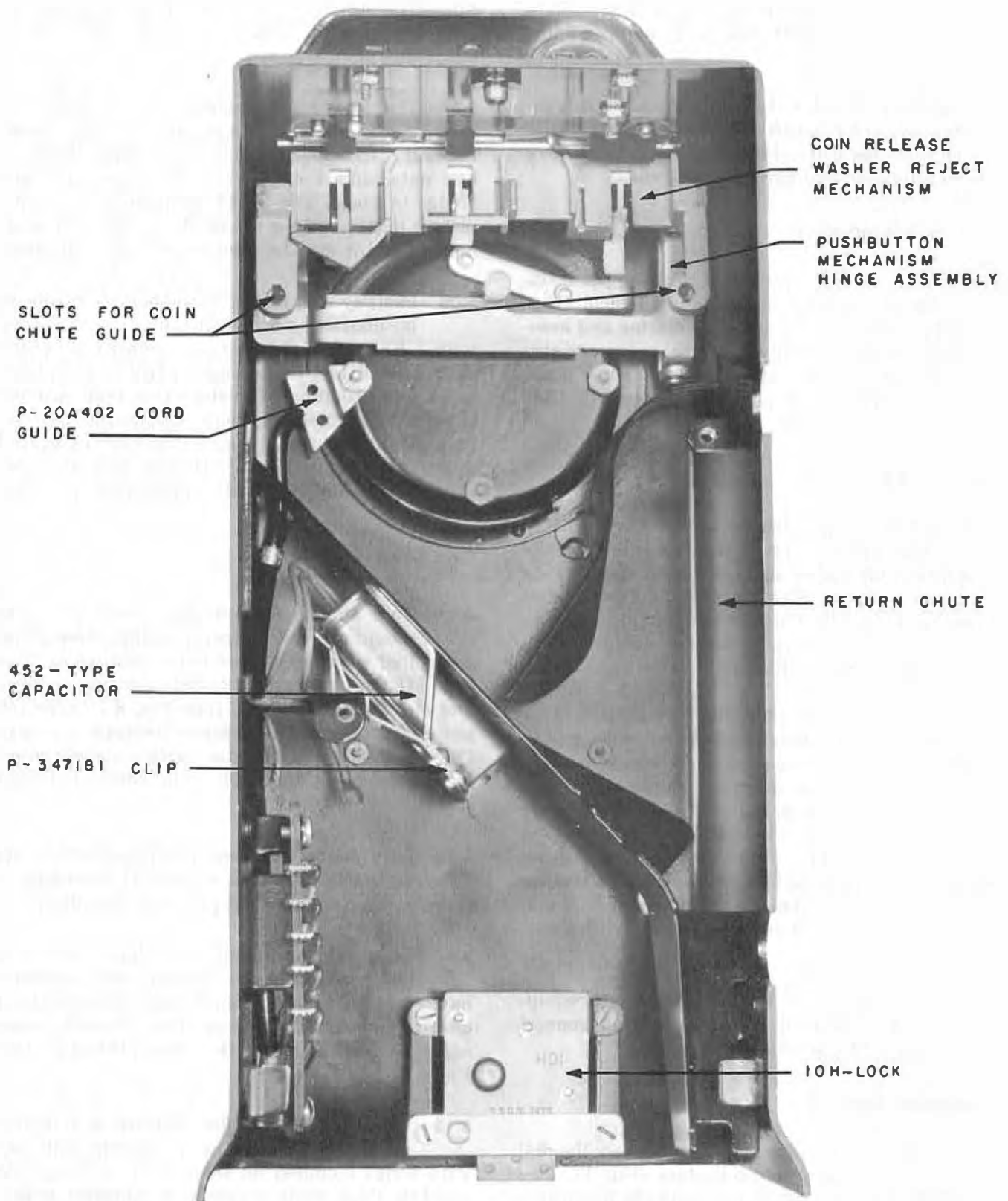

Fig. 9 - Upper Housing, Interior View



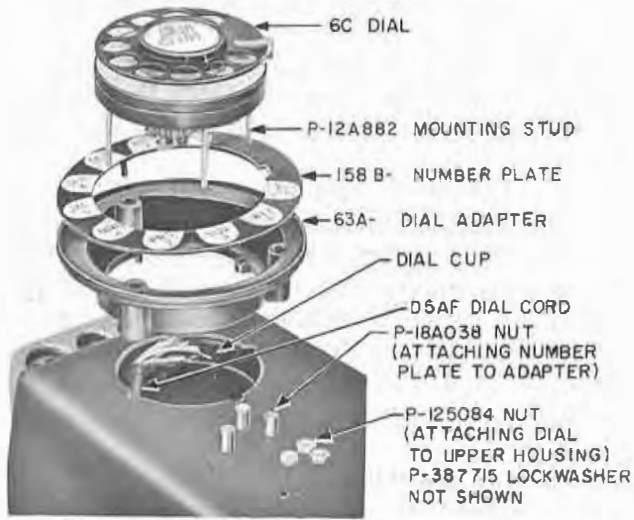

Fig. 10 - Assembly of 6-Type Dial



Fig. 12 - Handset Type Coin Collector

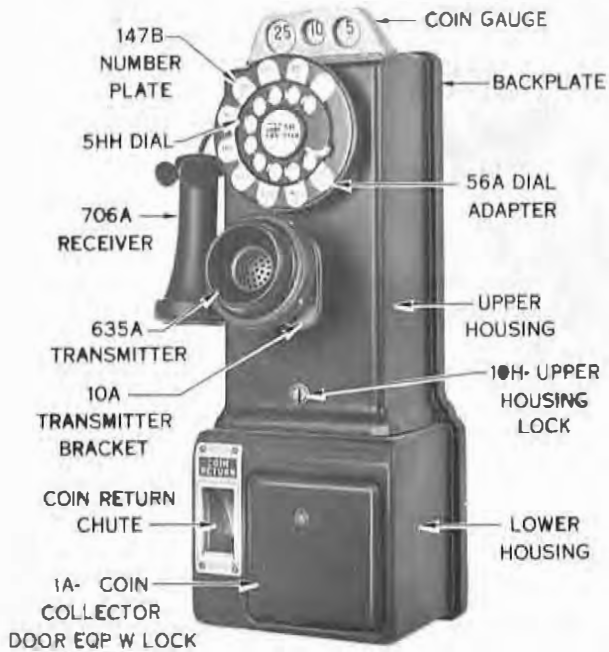

Fig. 11 - Transmitter Receiver Type Coin Collector

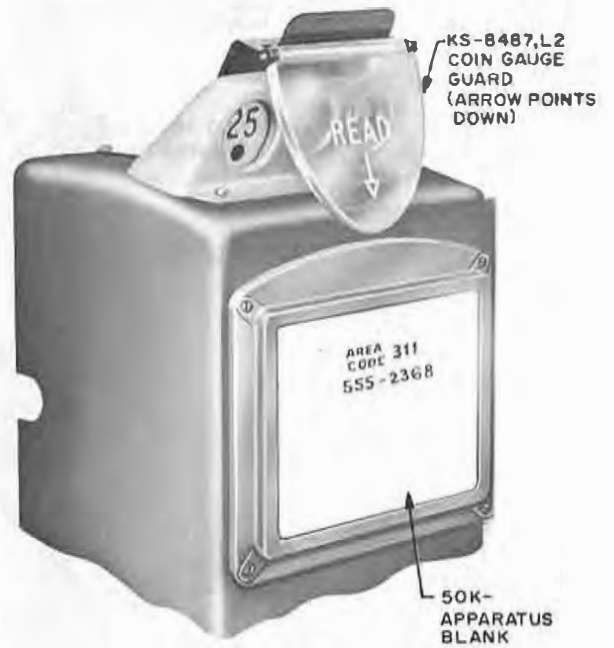

Fig. 13 - Manual Postpay Coin Collector Equipped with Coin Gauge Guard



Fig. 14 — Dial Postpay Coin Collector  
Equipped with Coin Gauge Guard

5.13 Manual postpay coin collectors may use a 10-cent prepay coin chute or coin chute assembly when the chute is equipped with a P-339098 cutover clip. The clip holds the electromagnet arm in its operated position. (See Fig. 15.)

5.14 A 61R radio-frequency suppression filter, although normally attached to the coin chute, is not considered a part of the chute assembly. The filter, when used, mounts on rear of coin chute at lower left corner. A mounting hole (Fig. 8) is provided. Dial postpay coin collectors are normally equipped with 61R filters and are identified by a red dot located on back of coin gauge.

**Upper Housing Assemblies**

5.15 Fully equipped upper housing assemblies used on the various types of coin collectors are shown in Tables B, C, and D. These vary according to type of service, coin features, and equipment.

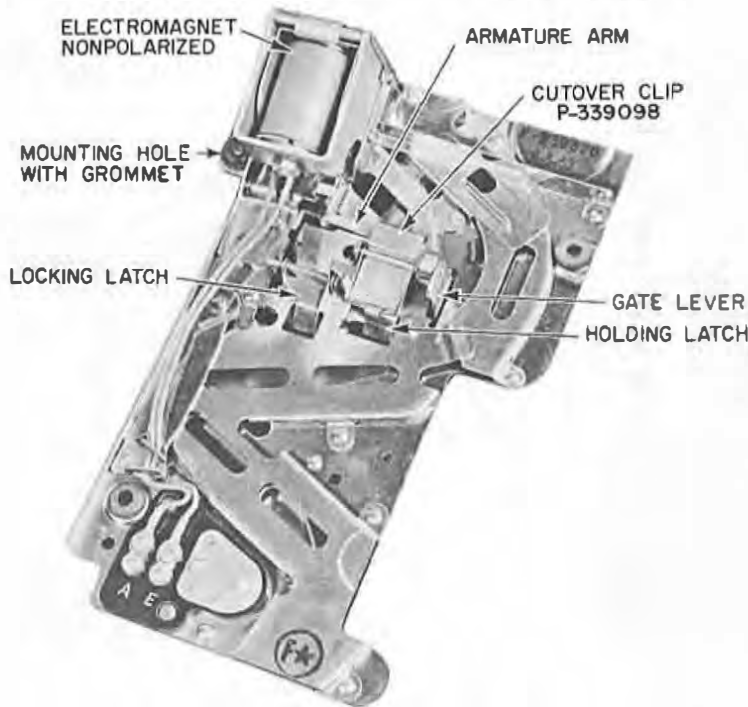

Fig. 15 — Prepay Coin Chute Equipped with Cutover  
Clip for 5-Cent Service

## 6. KS-19277 LOCK AND ASSOCIATED PARTS

6.01 The KS-19277 lock (Fig. 16) and associated parts (Fig. 17) are designed to give additional security to upper housing. The arrangement consists of a screw type lock and appropriate fasteners which secure upper housing to either backplate or mounting surface.



Fig. 16—KS-19277 Lock Assembly and Key

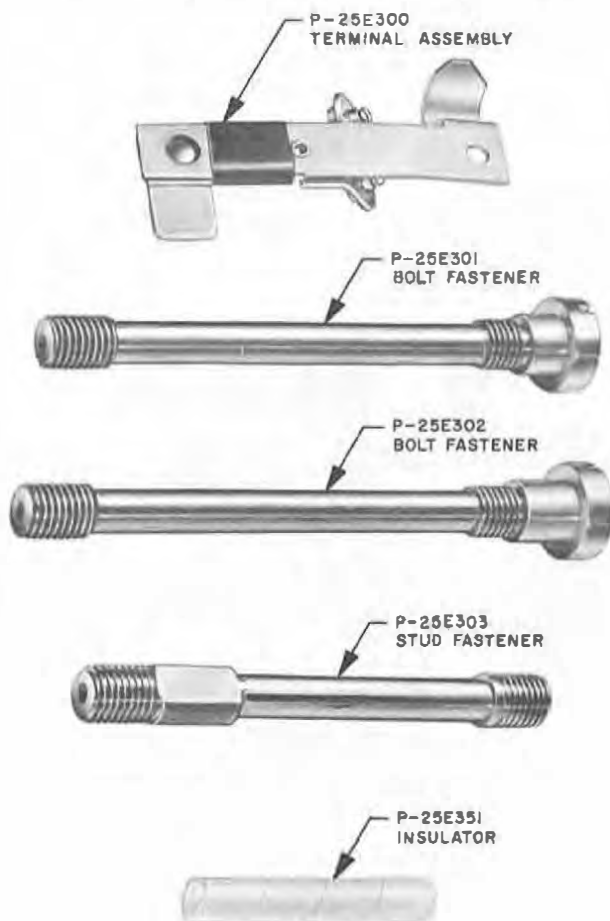

Fig. 17—Terminal Assembly, Associated Fasteners, and Insulator



Fig. 18—Coin Collector Equipped with KS-19277 Lock

6.02 The lock (Fig. 18) mounts in a specially provided hole in lower right side of upper housing. Providing this hole is a difficult operation and it is not recommended that it be done in the field.

6.03 The lock is held in place by a spring steel washer and heavy steel nut (Fig. 19). Use of the tubular key permits back of lock to rotate, and screw on to end of the security fastener.

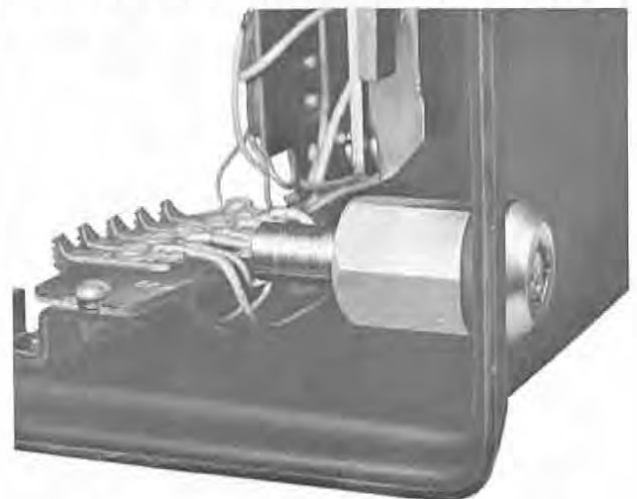

Fig. 19—Cutaway Section of Upper Housing, KS-19277 Lock Assembly Installed

## SECTION 506-110-101

**6.04** The lock cannot be used on 1A-type coin telephones (Fig. 20), coin collectors equipped with 2-coil relays, or those without a lower right security stud hole.

**6.05** The P-13A091 BKX terminal assembly (Fig. 21) must be replaced with a P-25E300 terminal assembly (Fig. 22 and 23) to provide clearance for fasteners.

### Fasteners

**6.06** The fasteners (Fig. 17) are:

- (a) Bolt fastener — P-25E301, short shoulder, for use on all mountings except the KS-16797 universal booth.
- (b) Bolt fastener — P-25E302, long shoulder, for use with KS-16797 universal booth.
- (c) Stud fastener — P-25E303.



**Fig. 20 — 1A1 Coin Telephone, Front View**

**6.07** Two methods may be used to determine if mounting surfaces on existing installations are equipped with four keyhole slots. This can be done without removing the coin collector from its mounting fixture. Check the following:

- (a) If a security stud is present in lower right security stud hole (Fig. 24), the appropriate bolt fastener (see 6.06) may be used after removing security stud.
- (b) If security stud is absent in lower right security stud hole, place a small-bladed screwdriver in this hole (Fig. 25). If blade enters to a depth of at least  $\frac{3}{4}$  inch, a keyhole slot is present (Fig. 26) and the appropriate bolt fastener (see 6.06) can be used. If the slot is missing, use stud fastener or modify or replace mounting surface to permit use of a bolt fastener.

### Bolt Fasteners

**6.08** Use of bolt fasteners is limited by the surface (backboards, shelf, or booth) upon which the coin collector is mounted. (See Table A.)



*In vulnerable locations where prying of upper housing is more likely, always use bolt fastener.*

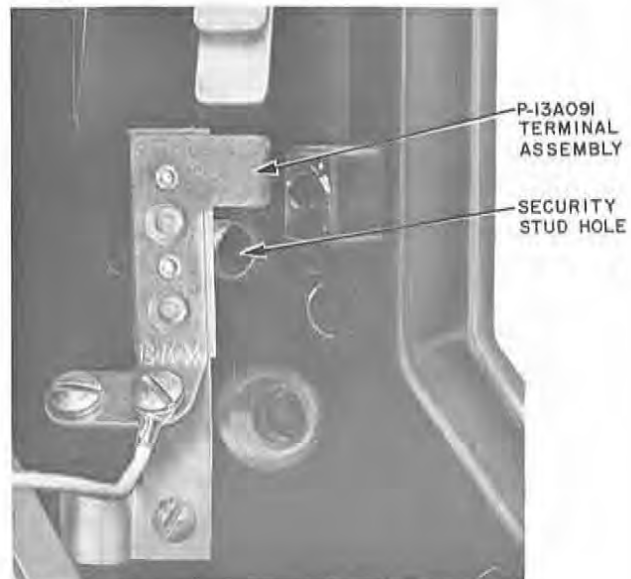

**Fig. 21 — P-13A091 Terminal Assembly and Vacant Security Stud Hole**

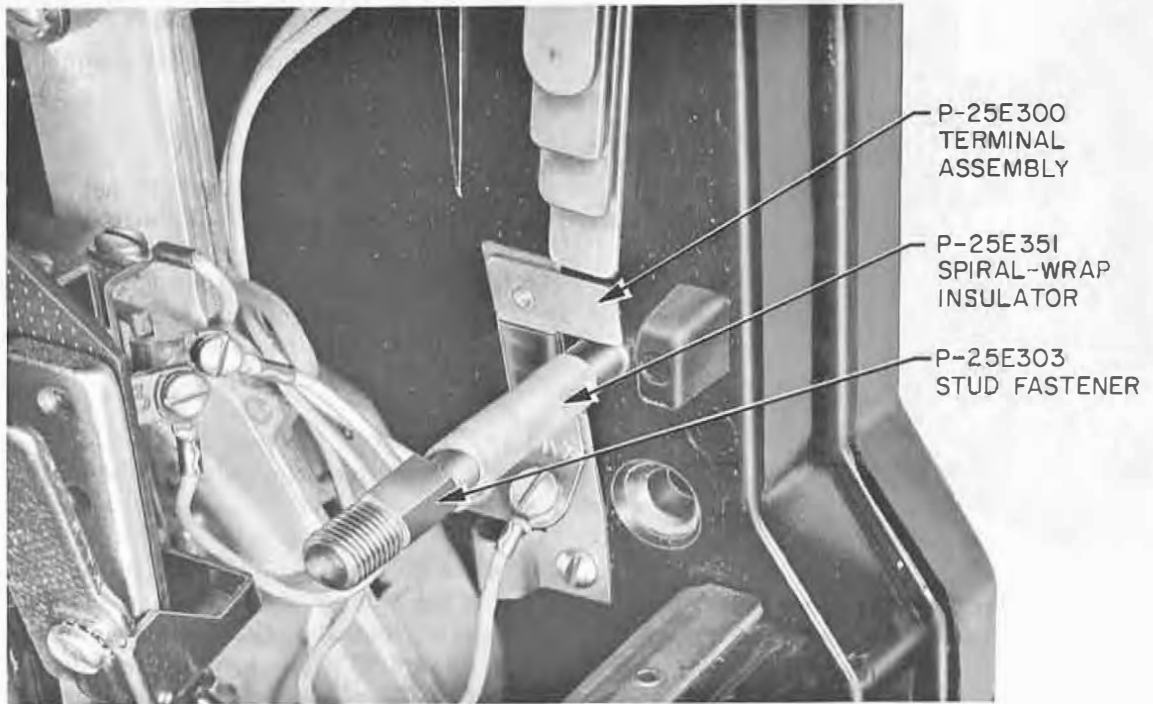

Fig. 22 — Terminal Assembly, Insulator, and Stud Fastener

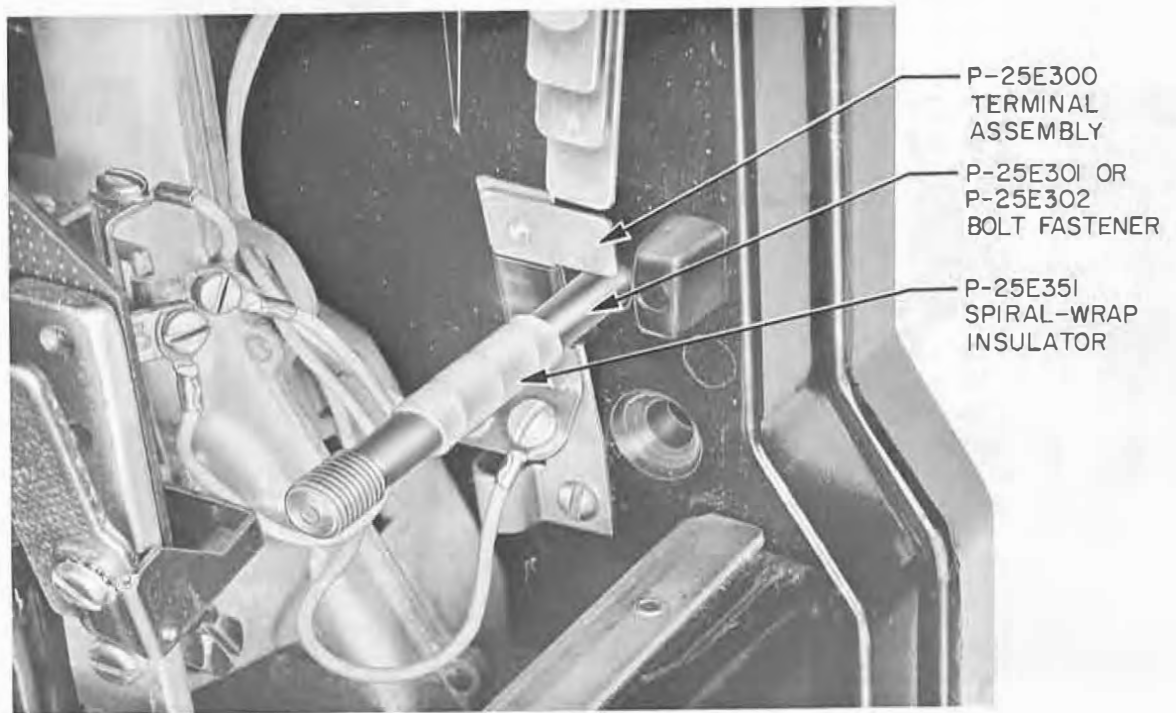
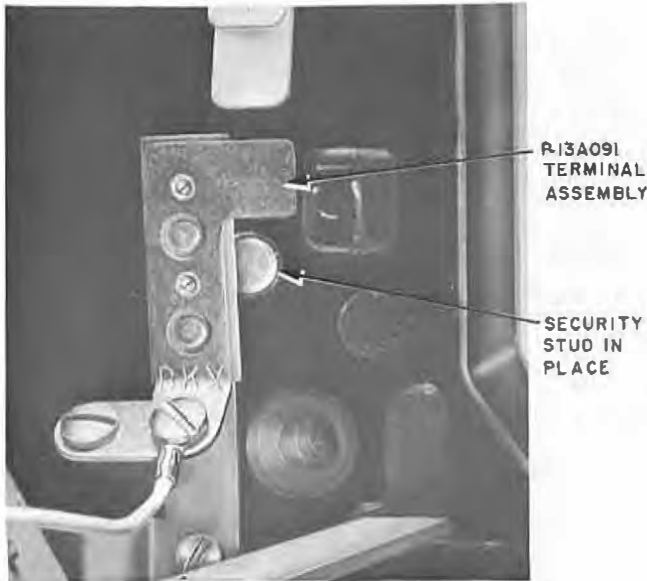

Fig. 23 — Terminal Assembly, Bolt Fastener, and Insulator



**Fig. 24 — Terminal Assembly and Security Stud Installed**

6.09 The P-25E301 and P-25E302 bolt fasteners screw from the rear into lower right security stud hole (viewed from front) of coin collector backplate. (See Fig. 23.) The coin collector is installed on mounting surface in same manner as any other coin collector equipped with security studs.



**Fig. 25 — Method of Determining if Mounting Surface is Equipped with Four Keyhole Slots**

6.10 To install bolt fastener on existing installations, it is necessary to disconnect and remove coin collector from its mounting surface.

**Stud Fastener**

6.11 Use of stud fastener is not restricted by mounting surface (Table A).

6.12 Use the P-25E303 stud fastener (Fig. 22) where maximum security is *not* essential, but where protection is desired against unauthorized use of upper housing key.

6.13 The stud fastener can be installed without removing coin collector from its mounting surface.

6.14 A P-25E351 spiral-wrap insulator surrounds the bolt or stud fastener (Fig. 17). Place insulator centrally around fastener shaft. (See Fig. 22 and 23.) The insulator eliminates the possibility of the fastener grounding out lower lug of housing contacts. Redress wiring to upper housing contacts. (See Fig. 27.)

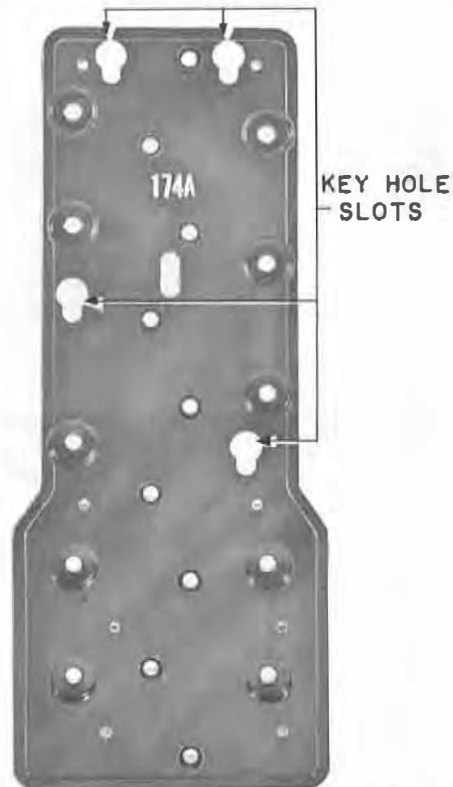

**Fig. 26 — 174A Backboard with Four Keyhole Slots for Security Studs and Bolt Fastener**



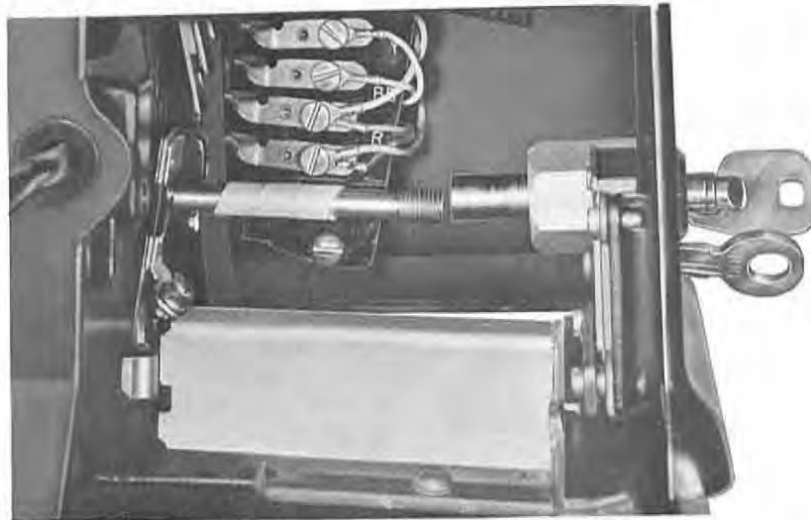

Fig. 27 — Cutaway Section of Upper Housing Showing Mating of Bolt Fastener and KS-19277 Lock with Housing Placed on Coin Collector

6.15 After bolt or stud fastener is properly installed, fasten upper housing as follows:

- (1) Insert KS-19277 tubular key into the KS-19277 lock.
- (2) Apply and maintain a slight forward pressure on key while rotating it in a clockwise direction until upper housing is tight against backplate.



*Do not force key beyond this point. Turn counterclockwise to first release position and remove key.*

## 7. LOWER HOUSING

### Cash Compartment

7.01 The self-locking coin receptacle and 1A coin collector door, equipped with lock for the cash compartment, are controlled according to arrangements with the Commercial Department.

7.02 The self-locking receptacle consists of a 1B coin receptacle equipped with a 1C coin receptacle cover. Use of coin receptacle requires a 1A or 1B coin receptacle rail on the mechanism base in the cash compartment. (See Fig. 28.)



Fig. 28 — Coin Collector Equipped with Coin Receptacle Booster Spring

7.03 The P-12E598 coin receptacle booster spring (Fig. 28) reduces the clearance between coin receptacle cover and rail. This prevents collected coins from falling out of their normal path onto coin receptacle cover. Coin collectors equipped with single-coil coin relays are provided with P-12E598 booster springs at the factory and repair shops. The spring will be added to coin collectors equipped with 2-coil coin relays when so specified by the telephone company.

#### Return Chute

7.04 The lower part of the coin return chute is located in the lower housing to left of the cash compartment. When a pull bucket is provided, it acts as a receptacle for returned coins. To remove coins, open pull bucket with handle marked COIN RETURN, PULL. The pull bucket, in both closed and open positions, prevents access to the return chute. The pull bucket assembly is covered in the section on coin collectors and pull buckets. The new coin collectors have P-15E011 chrome-plated pull bucket assemblies.

#### Backplate Assembly

7.05 Various combinations of parts mounted on the backplate are illustrated in Fig. 2, 3, and 4.

7.06 The 1A backplate (Fig. 29) is used on coin collectors arranged for security studs, bolt fasteners, and stud fasteners at locations where additional mounting security is needed. The 1A backplate provides clearance holes for security studs and mounting screws. It is fastened on the coin collector backplate by replacing the four lower housing assembly screws with four P-12E799 high-strength flat-head steel screws. The replacing screws must be ordered separately. Coin collectors equipped with the 1A backplate cannot be used on 139A backboards and 19-type shelves.

7.07 The 234G coin collector (Fig. 30) is furnished with a 1A backplate and is *always* installed with security studs, bolt or stud fasteners, and KS-19277 lock assembly. (See Fig. 16 and 17.)



Fig. 29 - 1A Backplate



Fig. 30 - 234G Coin Collector with 1A Backplate

### Switchhook Assembly

7.08 New coin collectors have 2-piece chrome-plated P-12E855 switchhook assemblies (Fig. 31). Coin collectors converted from transmitter-receiver type to handset type use P-10C139 switchhook assemblies which require a P-10C136 auxiliary spring.

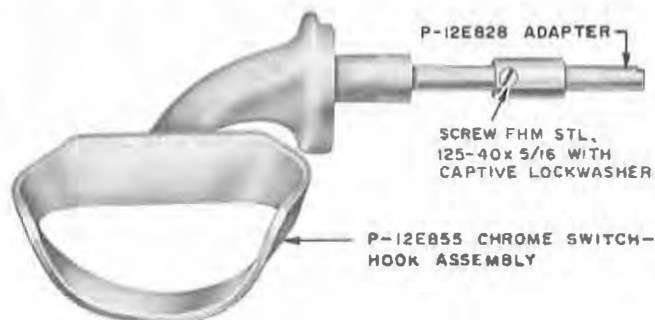

Fig. 31 — 2-Piece Switchhook Assembly

### Mechanism Unit Assembly

7.09 The mechanism unit assembly mounts on lower housing top. Four types shown are:

- Manual postpay, no coin relay (Fig. 32).
- Dial postpay, no coin relay (Fig. 33).
- Manual or dial prepay, 2-coil coin relay (Fig. 34).
- Manual or dial prepay, single-coil coin relay (Fig. 35).

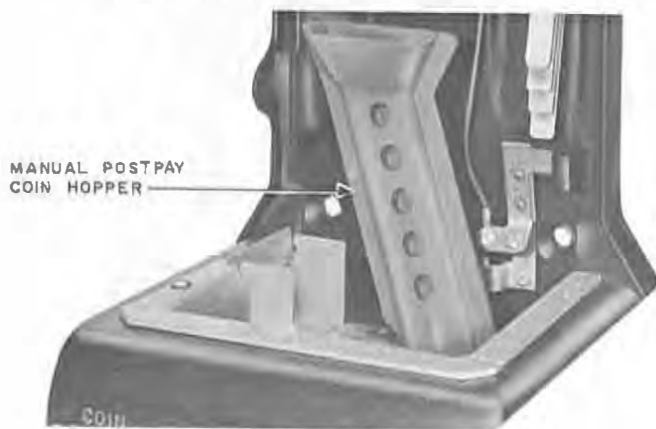

Fig. 32 — Manual Postpay

7.10 All new mechanism bases have a steel strip welded on the front to reinforce the lock strike (Fig. 4).

### Coin Relay

7.11 The P-145749 coin relay has two coils and two spring contacts for ground only. It has no dial shorting feature.

7.12 The P-10C117 coin relay has two coils and four spring contacts for ground and dial shorting.

7.13 The D-96590 coin relay is used only on D-series coin collectors. It has two coils and three spring contacts for grounding and dial shorting.

7.14 The P-10E786 coin relay is a single-coil, slow-release relay. It has four spring contacts for grounding and dial shorting.

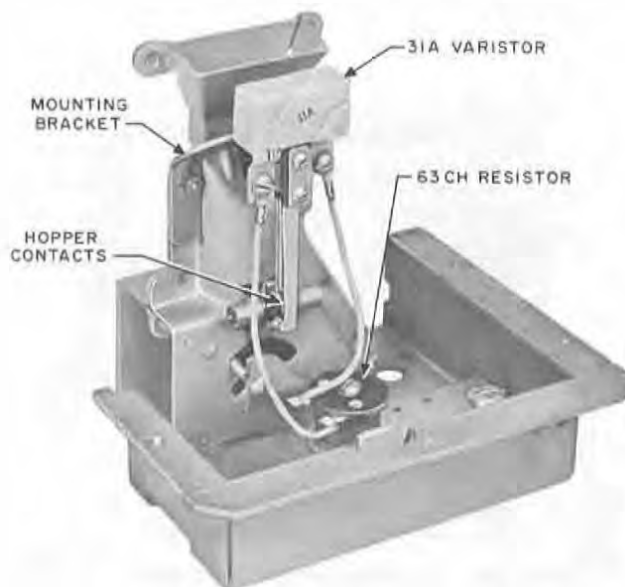

Note: New collectors have 146A resistor instead of 63CH.

Fig. 33 — Dial Postpay (CDO)

**SECTION 506-110-101**

7.15 New No. 230, 233, and 234 coin collectors are equipped with a new P-13E961 coin relay (Fig. 35). It replaces the P-10E786 coin relay rated Manufacture Discontinued. The relays are interchangeable, but some of the components are not.

7.16 The single-coil relay has a P-10E783 cover. The 2-coil relay has either a KS-7994 or P-349486 cover.

**8. COIN COLLECTOR APPARATUS — COLOR**

8.01 Coin collector apparatus for dial service, colors, and identifying code suffixes are listed in Table E. Include appropriate suffix when ordering apparatus.

**9. COIN COLLECTOR CODES**

9.01 Coin collector types are identified by numerical codes. Types of service, coins, and features are identified by letter codes. D specification numbers identify sets for limited use. Dial postpay coin collectors and their features are listed in Table B. Manual postpay coin collectors and their features are listed in Table C. Manual and dial prepay coin collectors and their features are listed in Table D.

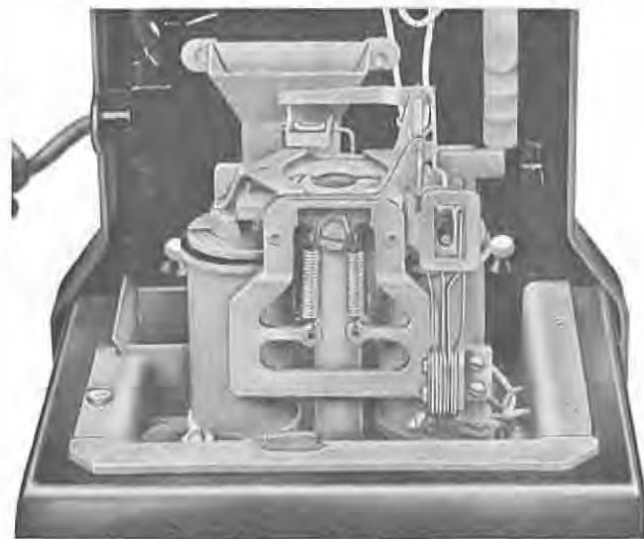

**Fig. 34 — Manual or Dial Prepay, 2-Coil Coin Relay**

**Code Numbers**

9.02 No definite plan or arrangement can be applied to lower-numbered codes or the relationship between old and converted code numbers. However, 2-digit numbers indicate sidetone telephone circuits and 3-digit numbers indicate anti-sidetone telephone circuits.

9.03 Code numbers for 180- and 190-series coin collectors use the same general coding plan with special features available on the 195, 196, 197, and 198 types. Other converted coin collectors, if applicable, are also coded to this plan. The 180 series is arranged for 5-cent initial deposit; the 190 series for 10-cent initial deposit. Both are handset types. Characters having common meaning are as follows:

**Third digit — service and special features**

180	}	1 — Prepay
or		2 — Postpay manual
190		3 — Postpay dial (CDO)
Series		

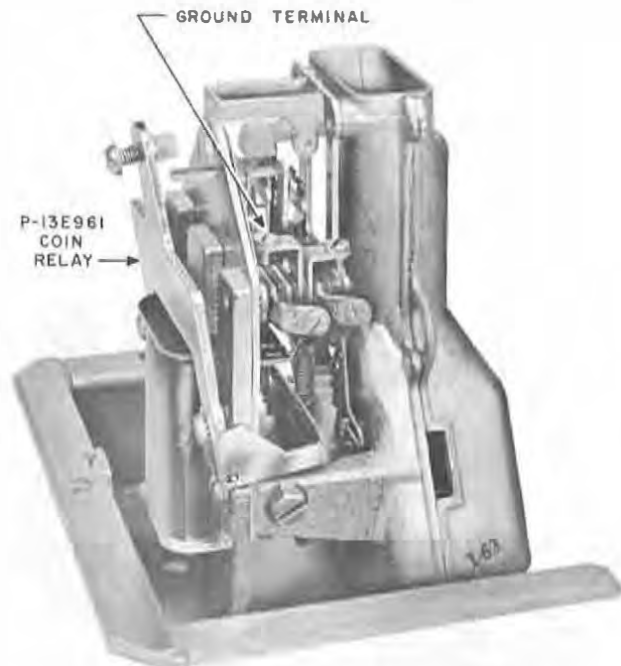

**Fig. 35 — Manual or Dial Prepay, Single-Coil Slow-Release Coin Relay**

- 190 Series Only
- 5 — Prepay equipped with pull bucket
  - 6 — Prepay equipped with washer reject
  - 7 — Prepay equipped with pull bucket and washer reject
  - 8 — Postpay dial equipped with washer reject (CDO)

9.04 The characters in 200-series coin collector code numbers have the following significance:

**First digit — telephone circuit**

- 2 — 425B network type telephone circuit

**Second digit — service**

- 0 — Manual postpay, 5-cent coin chute
- 1 — 10-cent dial postpay (CDO)
- 2 — 10-cent prepay, 4-spring dial shorting coin relay
- 3 — 10-cent prepay, slow-release single-coil dial shorting coin relay. Coin collector has corrosion-resistant finish.

**Third digit — features**

- 0 — Basic collector
- 2 — Washer reject
- 3 — Pull bucket and washer reject
- 4 — Pull bucket, washer reject, and added security features.

9.05 All 200-series coin collectors have cast aluminum backplates. Lower numbered codes have cast iron backplates.

**Code Letters**

9.06 Code letters associated with types of coin collectors indicate various types of service, features, and equipment. These letter codes apply to coin collectors in general:

**First letter — service and coin features**

- C — Manual, U.S. coins
- D — Manual, U.S. and Canadian coins
- E — Dial, U.S. coins (A-type number plate)
- F — Dial, U.S. and Canadian coins (A-type number plate)
- G — Dial, U.S. coins (B-type number plate)
- H — Dial, U.S. and Canadian coins (B-type number plate)
- \*L — Local battery talking, common battery signaling (obsolete).

\* These coin collectors will not be reissued from the repair shop.

**Second, or second and third letters — features added by conversion**

- N — 425B network type telephone circuit
- R — Spring cord (stamped on carton only)
- S — 4-spring dial shorting coin relay
- T — Slow-release, single-coil dial shorting coin relay.

**TABLE A**  
**REQUIREMENTS FOR KS-19277 LOCK AND ASSOCIATED PARTS**

Type Security	Coin Collector	Mountings			
		Back-Board	Shelves	Booths & Mountings	Notes
<b>MAXIMUM</b> Bolt fastener P-25E301 and P-25E302*	All coin collectors equipped with four security stud holes except those equipped with two coil coin relays.	167 and 174 Type (Note 1)	20 type	10 & 11 Type (Note 3) KS-14611 (Note 2) KS-16705 KS-16797*	<i>Note 1:</i> It is recommended that wall mounted coin collectors be mounted on a 174-type backboard. <i>Note 2:</i> Earlier KS-14611 booths were equipped with none or only two key-hole slots in collector mounting surface. <i>Note 3:</i> Earlier 167- type backboards were equipped with none or two key-hole slots.
<b>MINIMUM</b> Stud fastener P-25E303		All		All	All

\* P-25E302 bolt fastener is to be used only on the KS-16797 booth.



TABLE B

10-CENT DIAL POSTPAY (CDO)

Type	Code and Associated Coins		Features											U. S. Coins			U. S. and Canadian Coins		
			Hand Set Type			Dial Type			Washer Reject	Net-work	Ind. Coil & Cap	Comb. Swhk & Trfr Assem	Wood Term. Strip	Separate Xmtr & Rcvr	Equipped Upper Housing	Chute Assembly	Chute Only*	Equipped Upper Housing	Chute Assembly
	U. S.	U.S. & Can.	F1	F2	G3	5 or 6	6												
158†	G	H								•		•	•	BA-220496G	P-340044		BA-220496H	P-340045	
168†	G	H							•		•	•							
177	G	H		•		•				•		•		BA-220498G		P-340042	BA-220498H		
178‡	G	H		•		•				•		•							
193	G	H	•			•				•		•		BA-220500G	P-340224		BA-220500H	P-340225	
	GN	HN			•		•		•		•			P-81C403¶					
210	G	H			•		•		•		•								
198	G	H	•			•		•		•		•		BA-220502G or P-10E126	P-20A127§	P-20A121	BA-220502H	P-20A128§	P-20A122
	GN	HN			•		•		•		•			P-81B603¶					
212	G	H			•		•		•		•								

Note: Red designates coin collectors which accept U. S. and Canadian coins. Black designates coin collectors which accept U. S. coins only.

\* Equipped with polarized electromagnet.

† Manufacture Discontinued.

‡ 178C and H converted to 425 network and G-type handset are recoded 193 GN and HN.

§ Equipped with P-349754 gong assembly.

¶ Color designated by last two digits, ie, (-3) black, (-51) moss green, (-60) beige.

TABLE C  
MANUAL POSTPAY (5-Cent Type Coin Chute)

Type	Code and Associated Coins		Features							U. S. Coins			U. S. and Canadian Coins		
			Hand Set Type			Net-work	Ind. Coil & Cap.	Comb. Swhk & Trfr Assem	Wood Term. Strip	Separate Xmtr & Rcvr	Equipped Upper Housing†	Chute Assembly	Chute Only	Equipped Upper Housing‡	Chute Assembly
	U.S.	U.S. & Can.	F1	F2	G3										
150*	K	L				•			•	•					
162*	A	B				•			•	•			BA-220492H		
	C	D				•	•		•						
152	C	D*		•		•			•				BA-220493D		
164†	C	D*		•		•			•						
182*	C	D	•			•	•								
	CN	DN			•		•				P-338889		BA-220494D	P-338900	P-338884
200	C	D			•		•						P-81B903§		

Note: Red designates coin collectors which accept U. S. and Canadian coins. Black designates coin collectors which accept U. S. coins only.

\* Manufacture Discontinued.

† 164C and D converted to 425 network and G-type handset are recoded 182 CN and DN.

‡ Equipped with P-349754 gong assembly.

§ Color designated by last two digits, ie, (-3) black, (-51) moss green, (-60) beige.

