

630, 1630, AND 2630 SERIES TELEPHONE SETS

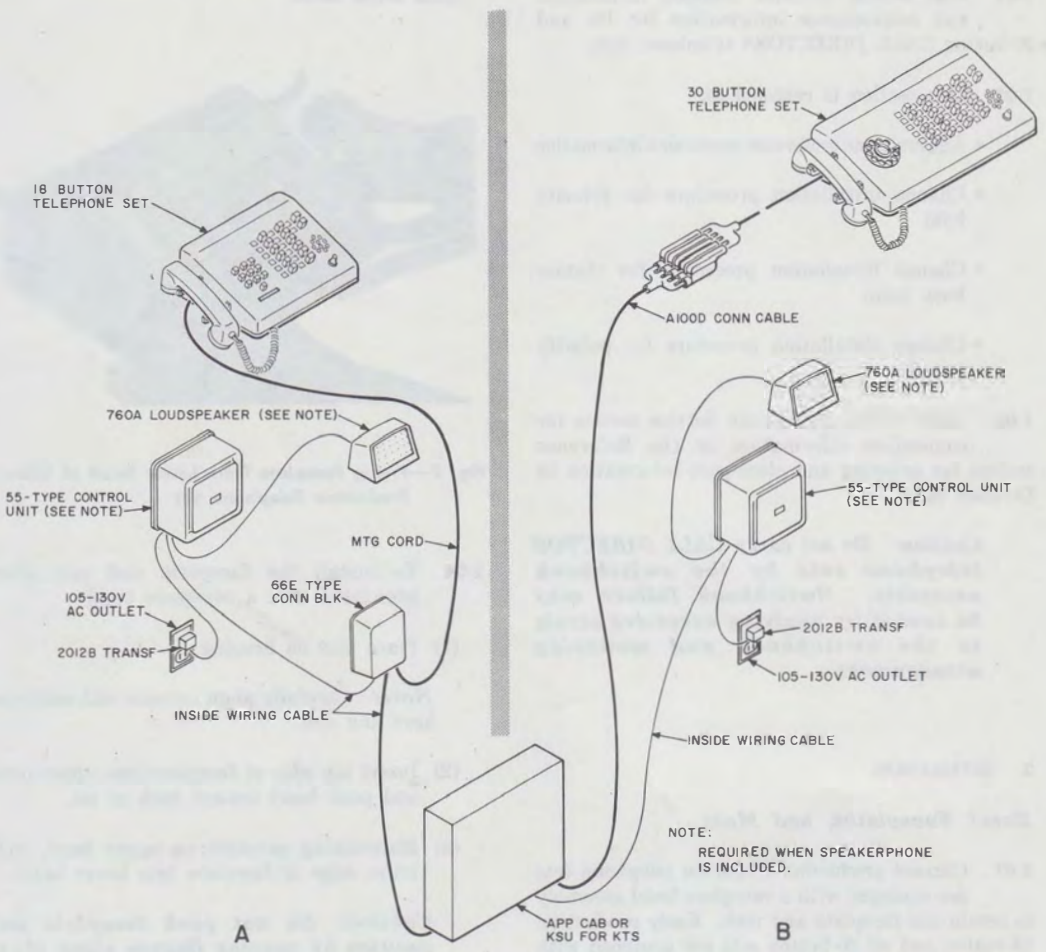

A—Using 66E-Type Connecting Block
B—Using a 100D Connecting Cable

Fig. 1—Two Typical Installation Layouts (Including Speakerphone)

NOTICE
Not for use or disclosure outside the
Bell System except under written agreement

1. GENERAL

1.01 This section contains common installation and maintenance information for 18- and 30-button CALL DIRECTOR® telephone sets.

1.02 This section is reissued to:

- Add multiline conference conversion information
- Change installation procedure for priority hold
- Change installation procedure for station busy lamp
- Change installation procedure for polarity guard.

1.03 Refer to the appropriate Service section for connection information or the Reference section for ordering and piece-part information in Division 502.

Caution: Do not carry CALL DIRECTOR telephone sets by the switchhook assembly. Switchhook failure may be caused by applying excessive strain to the switchhook and mounting arrangement.

2. INTALLATION

Bezel, Faceplates, and Mats

2.01 Current production 18-button telephone sets are equipped with a two-piece bezel assembly to retain the faceplate and mat. Early production 18-button and all 30-button sets are equipped with a one-piece bezel assembly.

2.02 To place key designation strips or remove the telephone set housing for component or wiring changes, the faceplate and mat must be removed.

2.03 To remove the faceplate and mat when associated with a two-piece bezel:

- (1) Pry with forefingers at both sides of faceplate near lower edge (Fig. 2).

- (2) This causes spring-loaded upper bezel to move until lower edge of faceplate disengages from lower bezel.



Fig. 2—Prying Faceplate From Lower Bezel of Current Production Telephone Set

2.04 To install the faceplate and mat when associated with a two-piece bezel:

- (1) Place mat on housing.

Note: Carefully align cutouts with collar on keys and dial.

- (2) Insert top edge of faceplate into upper bezel and push bezel toward back of set.

- (3) Maintaining pressure on upper bezel, snap lower edge of faceplate into lower bezel.

Caution: Do not push faceplate into position by running fingers along sharp edge of lower bezel. If faceplate does not seat properly, repeat removal and placing procedure.

2.05 To remove the faceplate and mat when associated with a one-piece bezel:

- (1) Pry gently at top of bezel to release spring clips.

- (2) Raise top edge of bezel to clear dial and key buttons.

- (3) Move toward back of set to release from guides on bottom edge of bezel.

2.06 To install the faceplate and mat when associated with a one-piece bezel:

- (1) Slide faceplate and mat into bezel.
- (2) Align cutouts in mat with those in faceplate and bezel.
- (3) Place guides on bottom edge of bezel into housing cutouts.
- (4) Lower bezel over dial and key buttons.
- (5) Press top edge to engage spring clips.

2.07 The one-piece bezel on early production 18-button telephone sets can be replaced with a two-piece bezel as follows:

- (1) Remove faceplate, mat, and bezel assembly (2.05).
- (2) Remove housing (2.09).
- (3) Install lower bezel 814455069 (P-44E506).
- (4) Secure with 997126610 (RM-712661) bezel clip (Fig. 3).
- (5) Place upper bezel 814455051 (P-44E505) on housing.
- (6) Turn housing over and place 814455077 (P-44E507) retainer on tab of bezel (Fig. 3).
- (7) Place 997126628 (RM-712662) bezel spring over retainer (Fig. 3).

2.08 The seeing aid probe guide for blind attendant operation consists of an 812263325 (P-22F332) retainer and guide assembly which is installed on telephone sets equipped with 590- or 650-series keys as follows:

- (1) Insert the clear plastic guide 812263317 (P-22F331) in retainer 812263309 (P-22F330).
- (2) Remove faceplate.

- (3) Remove designation strip and trim off a portion covering the lamps adjacent to key collars.

- (4) Insert retainer tabs in key holes in faceplate.
- (5) Engage tabs to the left side of key opening so that the retainer tabs contact the bottom surface and the retainer base rests on the top surface of the faceplate (Fig. 4).
- (6) Replace the trimmed designation strip and faceplate.

Note: One assembly per key is required and is held in position adjacent to the designation strip by the key collar. See Division 534 for information on the J-53128 lamp signal detector used with these assemblies.

Housings

2.09 Remove the telephone set housing as follows:

- (1) Remove faceplate and mat (2.03 or 2.05).
- (2) Loosen two screws at rear of housing (Fig. 5).
- (3) Raise rear of housing, move forward to disengage front mounting hooks, and lift off.
- (4) When replacing housing reverse procedure.

Keys

2.10 Current production double or triple letter coded CALL DIRECTOR telephone sets are equipped with 635-type or 658A keys, and early production single letter coded sets are equipped with 590- or 650-series keys. Installation and electrical connection of key modules for current and early production sets differ.

2.11 Remove the key module from early production telephone sets as follows:

- (1) Remove set housing (2.09).
- (2) Loosen screw at each end of key module.
- (3) Grasp both ends of key and lift upward to disconnect connector.

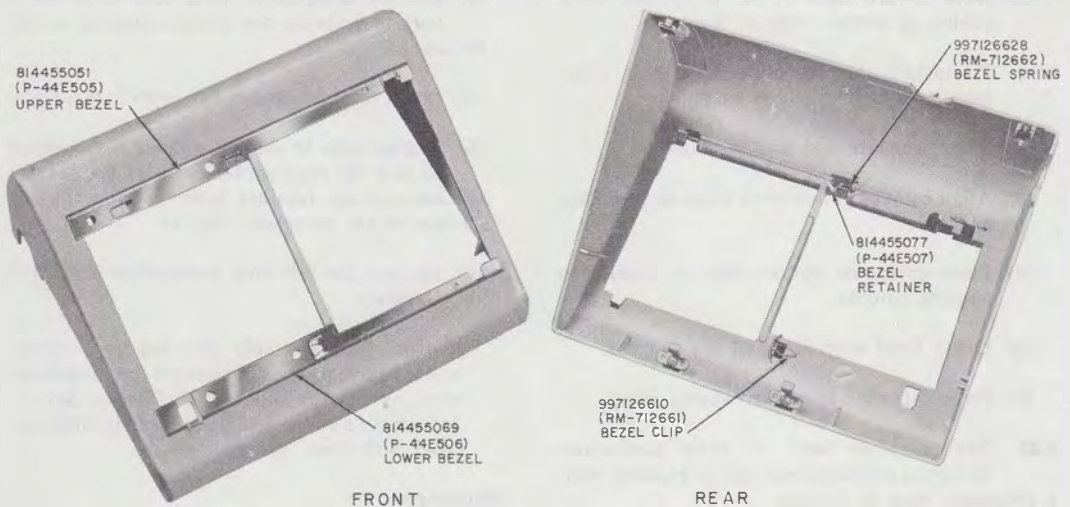

Fig. 3—Housing With Two-Piece Bezel Assembly Installed

- (4) Move key toward rear of set until front end clears mounting frame.
- (5) Raise front end of key—move forward and up to remove.

2.12 Install the keys (590- and 650-series) in the early production telephone sets as follows:



Before installing additional keys or replacement keys, check for free pivot bar motion and proper return spring action (Fig. 6).

- (1) Install the desired key and tighten mounting screws. Check for clearance between pivot bar and connector mounting bracket on key.
- (2) Depress the top button (first line pickup) of the key in left-most position until its bar moves to its forward-most operating position and hold in this position. Do not lock down.
- (3) While holding the (reference) key latchbar as in (2), slowly depress the top button of the key and observe the effect of its latchbar on the pivot bar. If the pivot bar moves significantly in the forward direction, the installed

key is positioned too high. To correct, loosen the screws and slightly lower the key until the pivot bar has no perceptible forward motion. Retighten screws.

- (4) Depress the top button of the installed key as in (2) and hold its latchbar in the forward-most position as in (3). Observe the effect of the latchbar of the (reference) key on the pivot bar while slowly depressing its top button. If the pivot bar moves significantly in the forward direction, the installed key is positioned too low. To correct, loosen the screws and very slightly raise the key until the pivot bar has no perceptible forward motion. Retighten screws and recheck (3).

Note: If an installed key does not meet the (no perceptible latchbar movement) requirement using this procedure, and there is reason to suspect that the reference key is out of position, reposition all keys as follows:

- (5) Loosen the screws of the (reference) key. With no buttons down and the latchbar held in, shift the reference key until latchbar notch is centered over edge of pivot bar (Fig. 6).

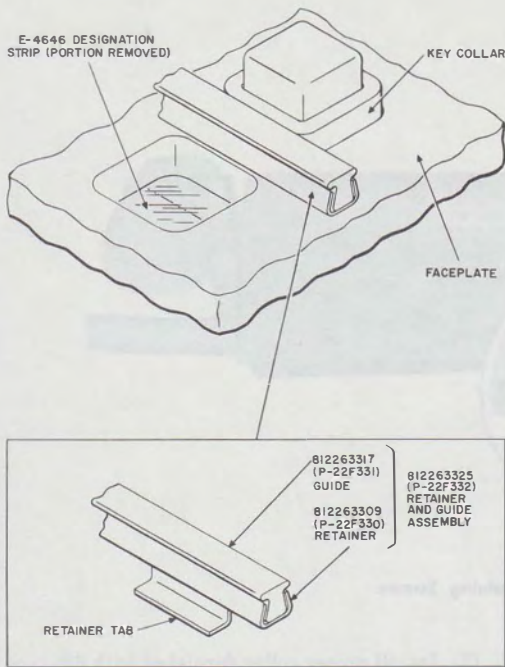

Fig. 4—812263325 (P-22F332) Retainer and Guide Assembly—Enlarged Cutaway End View

Tighten screws while maintaining key and latchbar position.

- (6) Moving from left to right, progressively position and check each key relative to the reference key as in (3) and (4).

Note: If the installed key still does not meet the (no perceptible latchbar movement) requirement replace key. It should not be necessary to apply undue force to move and position the 590- and 650-series keys.



Remove latch-bar return spring and retaining pin on key when adding or replacing keys.

- (7) Install key designation strip, light shield, housing, mat, and faceplate as required.

2.13 Remove keys (635-type) from current production telephone sets as follows:

- (1) Loosen captive screws at each end of key module.
- (2) Lift key out of key frame disengaging key latch arm from pivot bar.
- (3) Turn key counterclockwise and unplug 508-type and 509A plugs (Fig. 7).
- (4) Remove contact strips from key module.

2.14 Install keys (635-type) in current production telephone sets as follows:

- (1) Install proper contact strips furnished with 635-type keys (Fig. 8).
 - (a) Key modules with six pick-up keys must be equipped with a 840157218 (green lead) and a 840157200 (red lead) contact strip.
 - (b) Key modules with five pick-up keys and a hold key must be equipped with a 840151138 (green lead) and a 840151120 (red lead) contact strip.
 - (c) Key modules with four pick-up keys, a hold key, and a cutoff key must be equipped with a 840151047 (green lead) and a 840151039 (red lead) contact strip.

- (2) Connect 508-type and 509A plugs to proper receptacles (Fig. 7).

Note: On initial installation the 508-type and 509A plugs should follow the same color sequence for each key module: Pink (Hold Key), Light Beige (Chaining Switch), Blue (Line 1), Orange (Line 2), Green (Line 3), Brown (Line 4), Slate (Line 5, Cutoff key, or transmitter), and White (Line 6).

- (3) Position key in key frame making certain that latch arm engages in the pivot bar.
- (4) Secure key with captive screws at top and bottom of key.
- (5) Test keys for proper operation (random test from module to module).

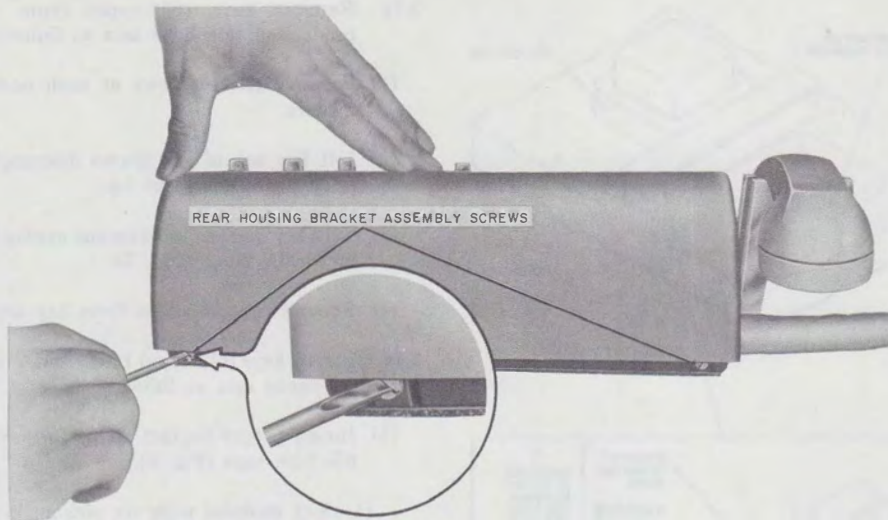

Fig. 5—Housing Retaining Screws

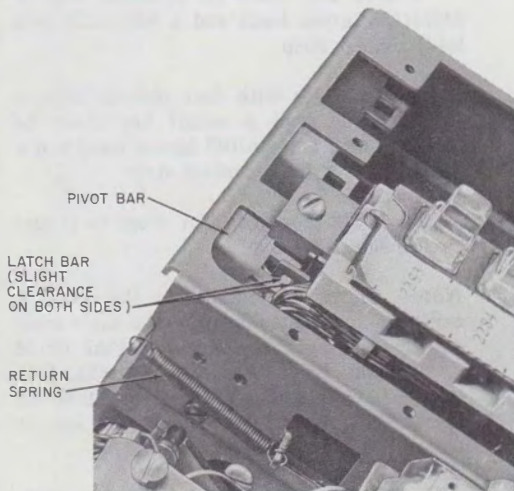

Fig. 6—Positioning 590 and 650 Series Keys

- (6) Remove caps and install key designation numbers.
- (7) Replace caps.

- (8) Install proper collar furnished with 635-type keys. Early production keys have rectangular buttons, and current production keys have square buttons (Fig. 9) making the collars incompatible.

Note: Due to the difference in shape of the buttons on early and current production key modules these keys are not compatible appearance wise and should not be intermixed in the same telephone set.

- 2.15** Lines on the current production telephone sets can be transposed from one key position or key module to another by moving the 508-type plugs on the back of the keys. Mounting cord conductors are of sufficient length to allow for complete flexibility of the 508-type plugs.

- 2.16** To convert locking pickup keys to nonlocking for signaling use:

- (1) Remove 811058379 (P-10E837) screw (598-, 599-, 656-, or 657-type keys) or the 812857738 (P-28E773) locking pin from 635-type keys.
- (2) Store screws or locking pin by taping to inside of set base.

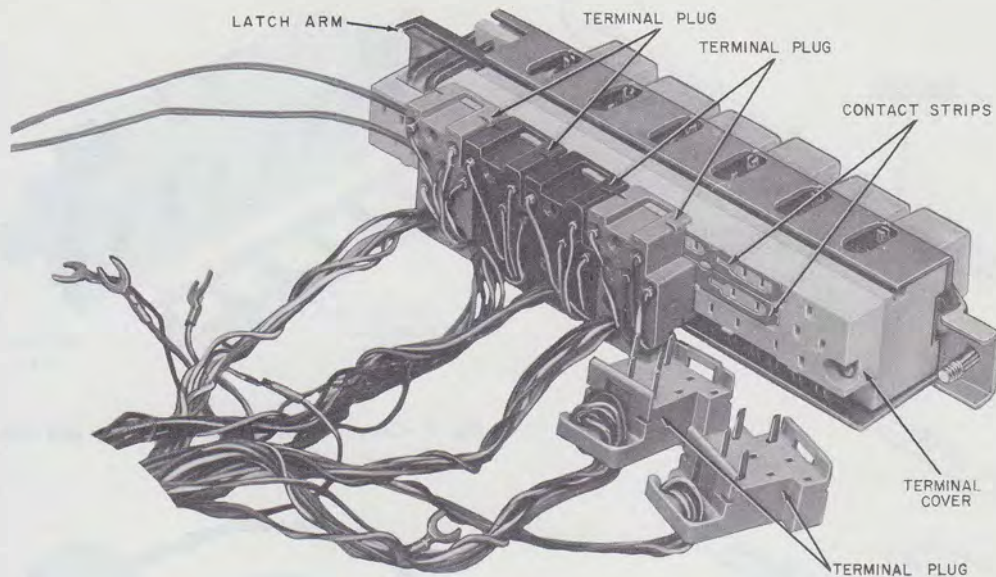

Fig. 7—Typical Connections to 635-Type Key

Note: When converting keys in concentrator type telephone sets from locking to nonlocking, an insulator must be installed over the key contacts associated with the operation of the concentrator units. (Refer to the section on modular keys in Division 512 for details on installing the insulator/insulating detail).

2.17 To provide a second hold button for the priority hold feature on early production telephone sets, install a 599H (MD) or 657L key in the first key position. Current production telephone sets equipped with 635-type keys will require the installation of all or part of a D-180411 Kit of Parts (depending on the type mounting cord) in the second key module. The kit consists of the following:

- 1—635A5C key
- 1—840151161 plug assembly
- 1—840151120 contact strip assembly
- 1—840151138 contact strip assembly

Note: Telephone sets equipped with D120K and D200S mounting cords use the complete kit of parts. Telephone sets equipped with D120M and D200AA mounting cords require the 635A5C key and 840151161 plug assembly only.

2.18 The 635AD5C key module is equipped to provide four pickup keys, one cutoff key, and a hold key. The key module is used in the first module of the telephone set and has to be equipped with 2 contact strip assemblies 2.14(1)(c) and a piggy-back adapter 840155501 (Fig. 10) accommodates the slate 508-type mounting cord plug.

2.19 The 811218585, (P-12A858) blocking ring is used to make an individual pickup key inoperative on the 598-, 599-, 656-, and 657-type keys and is installed as follows:

- (1) Remove lamp block assembly from key (Fig. 11).
- (2) Remove button retainer.

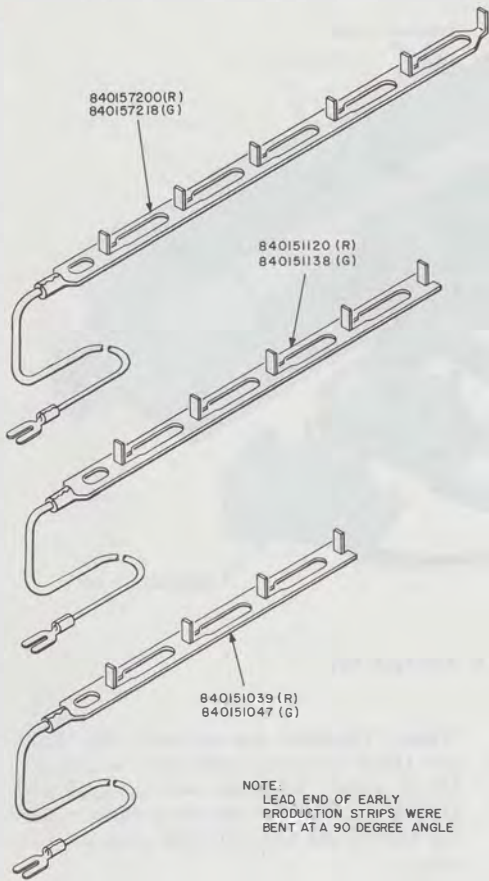

Fig. 8—Contact Strip Used With 635-Type Keys

- (3) Place blocking rings in plungers to be blocked.
- (4) Reassemble button retainer and lamp block assembly.

2.20 The 812365948 (P-23F594) button stop is used to make an individual pickup key inoperative on the 635-type key and is installed as follows:

- (1) Remove collar.
- (2) Remove button and cap.

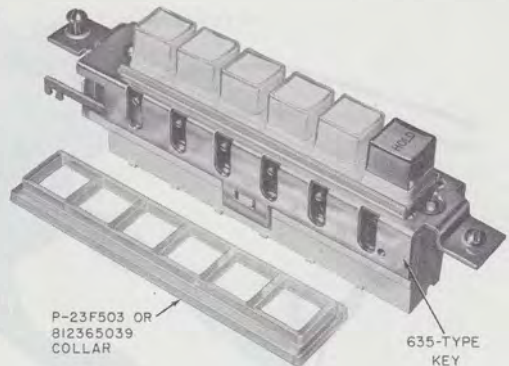

Fig. 9—Current Production 635-Type Key and Collar

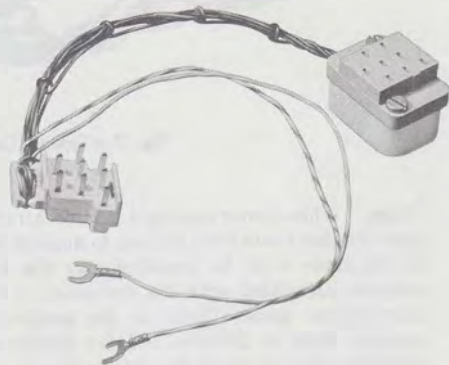

Fig. 10—810155501 Adapter

- (3) Place button stop over lamp (Fig. 12).
- (4) Reinstall button, cap, and collar.

2.21 Any unused key module should be replaced by a 105B (early production sets) or a 111B (current production sets) apparatus blank.

2.22 Insulate and store unused 508-type plugs on the 111B apparatus blank as shown in Fig. 13. Individual 508-type plugs can be insulated and stored by taping an 814632659 (P-46C265) cover over the contacts of the plug.

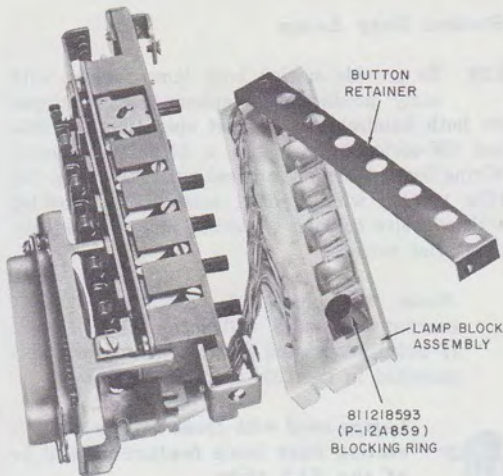

Fig. 11—Blocking Ring Installed In 590 or 650 Series Keys

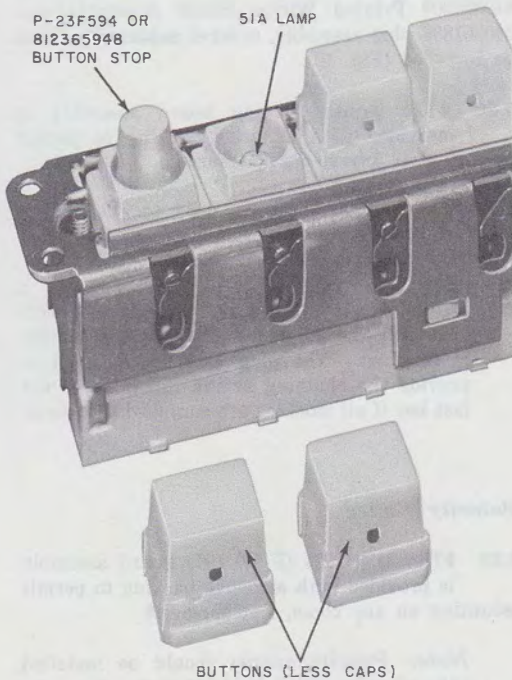

Fig. 12—Button Stop Installed in 635-Type Key

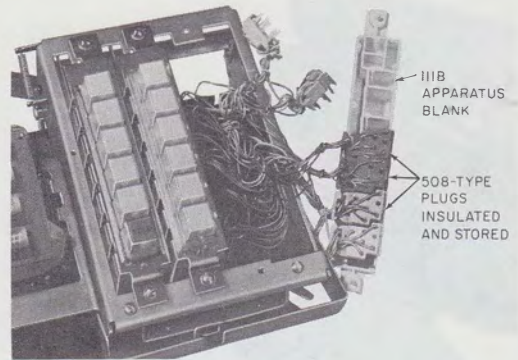

Fig. 13—Insulating and Storing 508-Type Plugs on 111B Apparatus Blank

2.23 ♦To provide multiline conference feature it is necessary to replace the keys. Refer to Section 512-230-104 for specific conversion procedure.♦

Dials

2.24 The dial mounting bracket will accommodate either a rotary dial or a TOUCH-TONE® dial. To interchange dials:

- (1) From TOUCH-TONE service to rotary, add 812651974 (P-26E197) and 812651982 (P-26E198) adapter bracket to rotary dial (Fig. 14).
- (2) From rotary to either 10- or 12-button TOUCH-TONE service, dial mounts directly to frame assembly.
- (3) Refer to appropriate Reference section for faceplate and mat ordering information.

Buzzers

2.25 Current model CALL DIRECTOR sets are furnished from the factory equipped with a KS-20419L1 (10 volt AC only) buzzer (Fig. 15).

2.26 In early model CALL DIRECTOR sets, KS-8100 type buzzers were mounted at location shown in Fig. 15 and 17.

2.27 If a second buzzer is required, a KS-20419L1 can be mounted at any convenient location using a single screw and KS-8109L2 at location shown in Fig. 15 or 17.



DIAL ADAPTER BRACKET
8I265I974
(P-26E197) FOR LEFT SIDE
8I265I982
(P-26E198) FOR RIGHT SIDE

Fig. 14—Placing Dial Adapter Brackets on Rotary Dial When Converting from TOUCH-TONE Dial

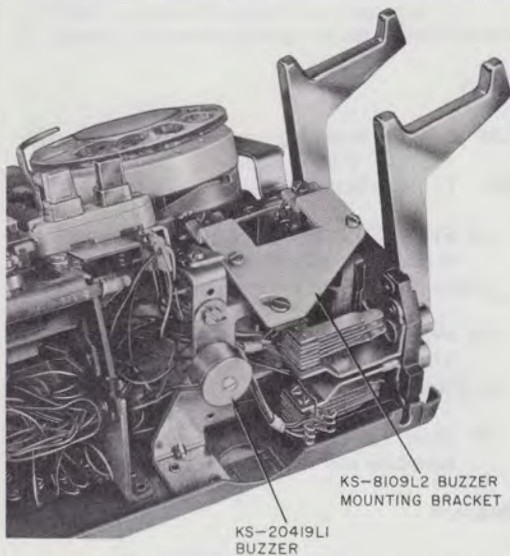

KS-8109L2 BUZZER MOUNTING BRACKET
KS-204I9LI BUZZER

Fig. 15—Mounting Location for First Buzzer

Note: Telephone sets manufactured between June 1964 and April 1966 and equipped with a one-piece bezel must have the 814454096 (P-44E409) bracket assembly [includes modified 814454107 (P-44E410) bracket, Fig. 16] installed before the KS-8109L2 buzzer can be mounted.

Station Busy Lamp

2.28 To provide station busy lamp feature with early production telephone sets equipped for both handset and headset operation and 590- and 650-series keys install a 840362909 Printed Wiring Board Assembly, ordered separately, (Fig. 18). ♦The printed wiring board assembly is provided with adhesive backing to permit mounting on any clean, flat surface.♦

Note: ♦Telephone sets associated with line concentrator units will have the 819040338 (P-90D033) printed wiring board assembly mounted in the 235- or 236-type KTU's.♦



Lamps used with these sets to indicate station busy lamp feature should be of the 51A type.

2.29 To provide station busy lamp feature with current production telephone sets equipped for both handset and headset operation and 635-type keys, a D-180463 Kit of Parts consisting of an 840362909 Printed Wiring Board Assembly and 840361836 plug assembly, ordered separately, must be installed (Fig. 18).

2.30 ♦The printed wiring board assembly is provided with adhesive backing to permit mounting on any clean, flat surface.

2.31 The plug assembly is used to extend the A lead through the chaining switch to the printed wiring board.♦

Note: If all modules are not equipped with keys only the printed wiring board assembly is required. The plug assembly is used to provide the chaining switch function for the last key if all modules are equipped with keys.

Polarity Guard

2.32 ♦The 819041971 (P-90D197) guard assembly is provided with adhesive backing to permit mounting on any clean, flat surface.♦

Note: Polarity guards should be installed only when specified by local instructions for end-to-end signaling purposes when battery and ground reversals are encountered.

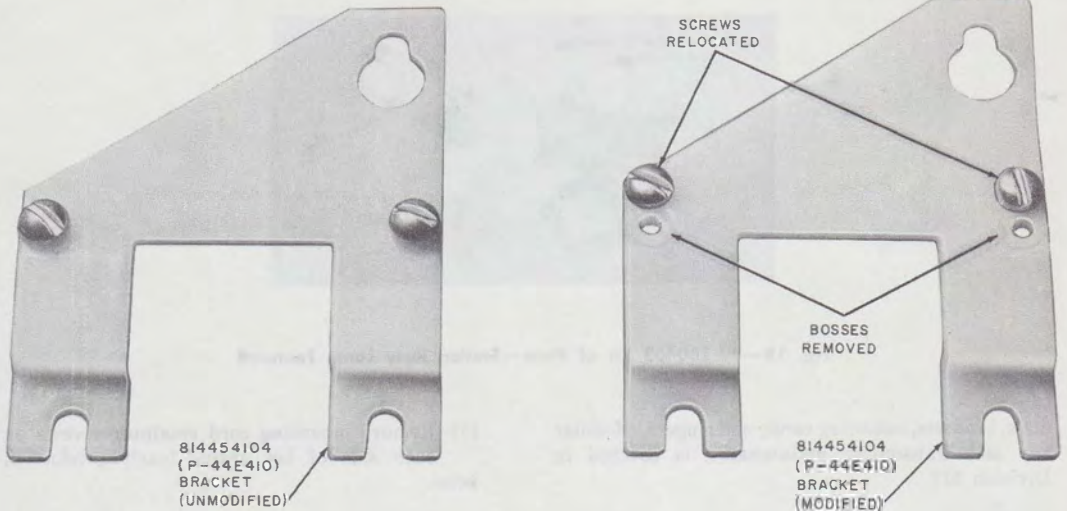

Fig. 16—Buzzer Mounting Bracket Assemblies

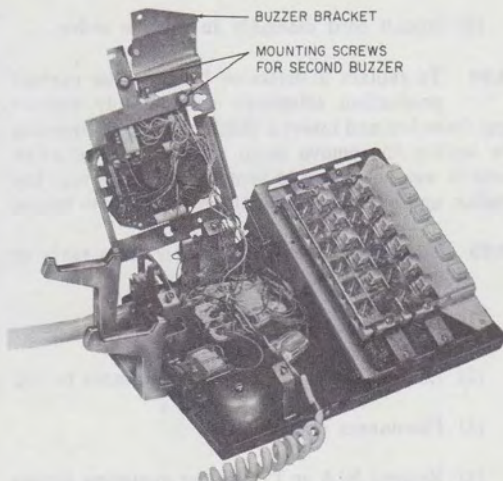

Fig. 17—Mounting Location For Second KS-8109L1 Buzzer

Speakerphone Transmitter

2.33 Telephone sets that are intended for use with speakerphone can be modified by

installing a 667-type transmitter (Fig. 19) for early production sets or a 679A transmitter (Fig. 20) for current production sets, and replacing the 8R dial with an 8C dial on rotary dial sets.

2.34 The 667-type transmitter is equipped with a connector which uses the plug of the 3rd key module on 18-button sets or the 5th key module on 30-button sets. The 679A transmitter is equipped with a receptacle block which accommodates the slate 508-type plug associated with the last key module.

Mounting Cord

2.35 After the mounting cord plugs are mated with the connectors on the connector cables the proper covers or service fittings should be used to protect the multiconductor connectors and plugs (see Division 461 for information on adapters, covers, and service fittings).

3. MAINTENANCE

3.01 Refer to the proper Reference section for ordering information on replaceable components.

3.02 Refer to appropriate section in Division 501 for maintenance information on handsets,

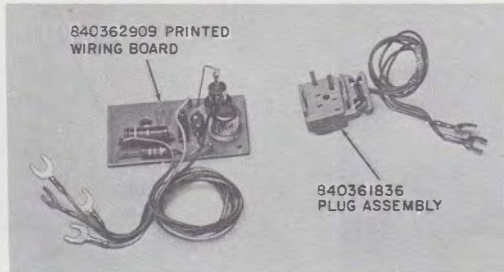

Fig. 18—D-180463 Kit of Parts—Station Busy Lamp Feature

dials, headsets, mounting cords, and ringers. Modular key and transmitter maintenance is covered in Division 512.

Caution: Do not carry CALL DIRECTOR telephone sets by the switchhook assembly. Switchhook failure may be caused by applying excessive strain to the switchhook and mounting arrangement.

3.03 To replace a mounting cord assembly:

- (1) Remove housing.
- (2) Remove mounting cord clamp.
- (3) Loosen key frame locking screws. [Located on front of key frame on current production telephone sets (Fig. 21) and on the side of key frame on early production sets (Fig. 22).
- (4) Raise key frame (Fig. 21 and 22).
- (5) Remove dial mounting plate (do not disconnect leads).
- (6) Disconnect mounting cord leads at network, terminal board, and amplifier (when provided).

(7) Remove mounting cord retaining screws on each side of key frame (early production sets).

(8) Pull down on mounting cord frame to disengage plugs from key connectors on early production sets or disconnect individual 508- or 509-type plugs on current production sets.

(9) Install cord assembly in reverse order.

3.04 To replace a defective lamp in the current production telephone sets, simply remove cap from key and insert a 553C tool through opening in button to remove lamp. In early production sets it was necessary to remove faceplate, cap, key collar, and button or shield to gain access to lamps.

3.05 To remove a defective ringer from early or current production sets:

- (1) Remove housing.
- (2) Loosen dial mounting plate and move to left.
- (3) Disconnect ringer leads.
- (4) Remove N1A or T1A ringer mounting screws from underside of baseplate (Fig. 23) or

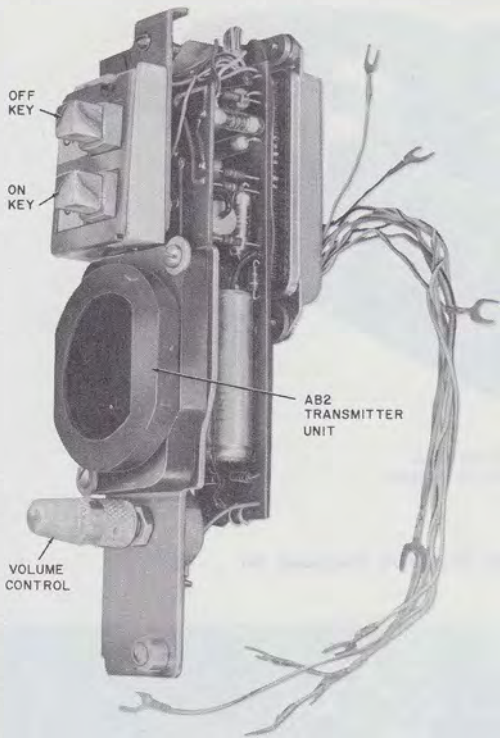

Fig. 19—667-Type Transmitter

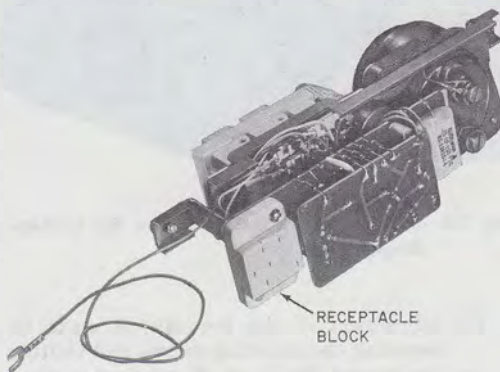

Fig. 20—679A Transmitter

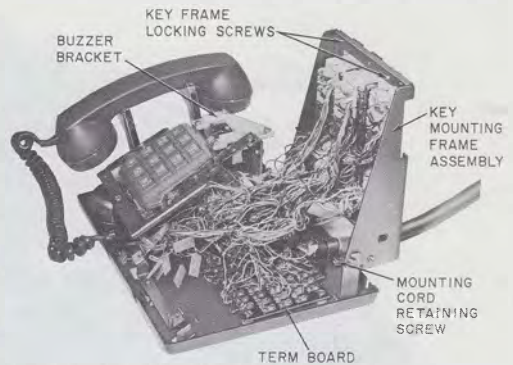

Fig. 21—Key Frame Raised in Current Production Telephone Set

loosen captive screws of D1-type ringers (Fig. 24).

(5) Lift out ringer.

3.06 The use of the head telephone set with jack equipped telephone set requires an amplifier to equalize the level of the N1 transmitter with the T1 transmitter in the handset. If the headset transmission is too loud or inadequate the 241-type amplifier should be replaced.

3.07 In early production sets a 151D amplifier is used. If the headset transmission is too loud replace the 30 ohm resistor on TB2 between terminals 3 and 4 with a 62 ohms KS-13490L1 1/2-watt resistor.

Note: If handset transmission is too loud check connections to the amplifier to insure that the handset transmitter output is not being amplified.

3.08 Two KS-14337 capacitors on terminals 1 and 5, and 2 and 6 may be replaced if defective. These capacitors are polarized electrolytics and polarity must be maintained.

3.09 When an operated pickup key does not remain depressed or release any previously operated key on early production sets refer to 2.12 and Fig. 6 for positioning information on these keys.

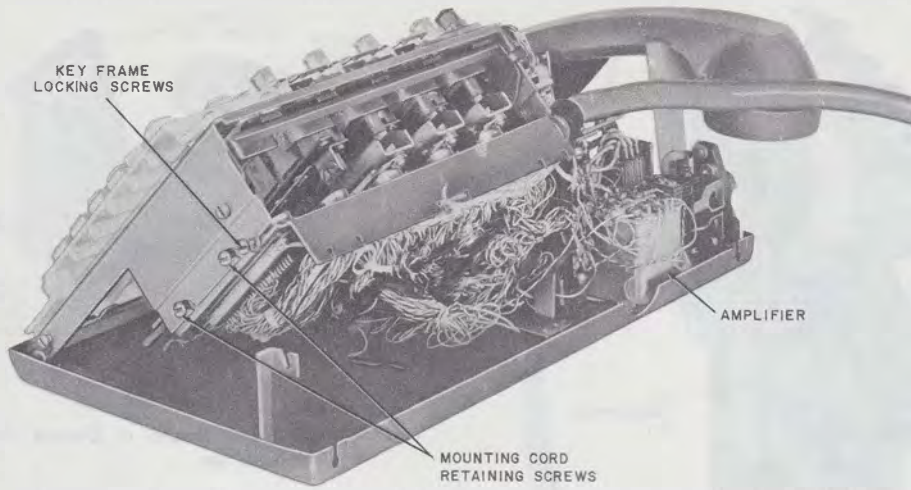

Fig. 22—Key Frame Raised on Early Production Telephone Set

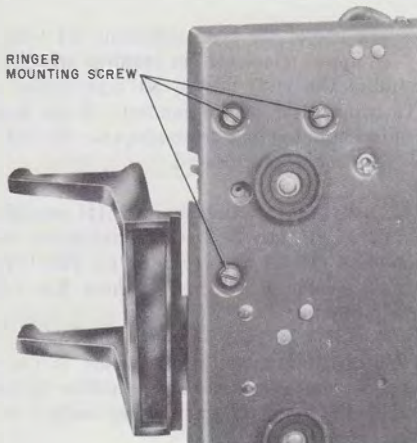

Fig. 23—Location of Mounting Screws for N1A or T1A Ringers

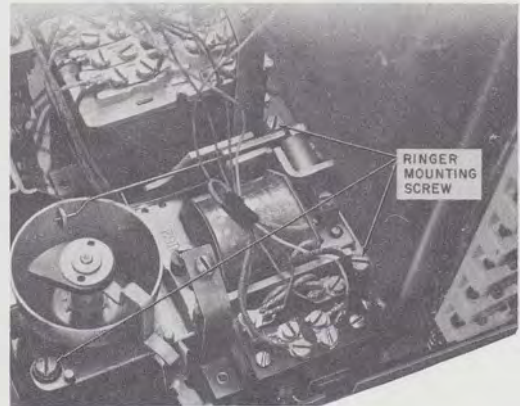

Fig. 24—Location of Mounting Screws for D1-Type Ringers

3.10 When an operated pickup key does not remain depressed or release any previously operated key on later or current production sets:

(1) Check that key latch arm is properly seated in the pivot bar (Fig. 25 and 26).

(2) Adjustment of the key can be made by loosening the mounting screws and shifting the key toward the front of set so that there is no play between the latch arm and pivot bar when a key is operated.

(3) If malfunction is related to one key module test key for proper operation.

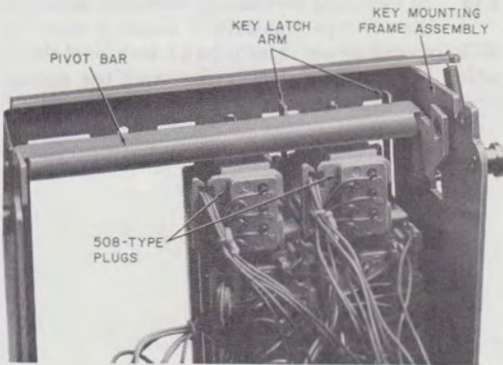

Fig. 25—Rear View of Pivot Bar (Current Production Set Equipped With 635-Type Keys)

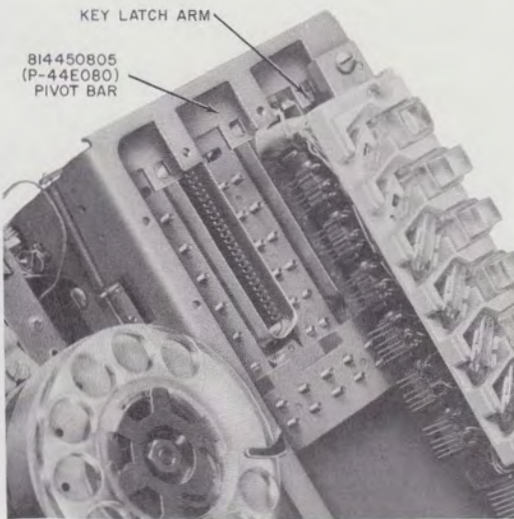

Fig. 26—Top View of One-Piece Bar (Later Production)

3.11 To prevent release button from binding on headset equipped early production telephone sets install a 811256726 (P-12E672) collar as follows:

- (1) Remove faceplate assembly.
- (2) Remove two switch assembly screws (Fig. 27).

- (3) Remove button assembly.
- (4) Place 811256726 (P-12E672) collar around 811159284 (P-11E928) plunger (Fig. 27).
- (5) Reassemble switch assembly.

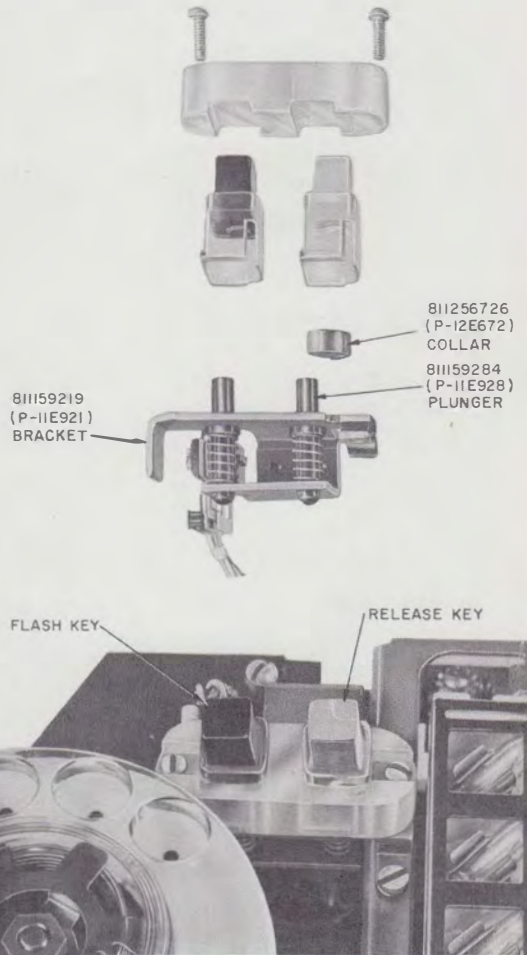

Fig. 27—811159872 (P-11E987) Switch Assembly

3.12 Improper operation of 667-type transmitters may be caused by interference between the printed circuit board and terminal screw of TBVI of the cord assembly. This condition can be

corrected by replacing 801808015 (P-180801) 5/16-inch machine screw with 801808007 (P-180800) 1/4-inch binder head machine screw.

Note: The longer screws were used in D50B, D80B, D120B, and D200B cord assemblies.

3.13 To eliminate mechanical vibration pickup in the 667-type transmitter install a modified 667B transmitter which includes a 1-inch vinyl sleeve which is to be placed over the pivot bar spring. Order as "Transmitter, 667B modified per D-180196."



Fig. 25 - New view of transmitter showing the sleeve over the pivot bar spring.



Fig. 26 - New view of transmitter showing the modified 667B transmitter.

Fig. 27 - The project cabinet shown from another angle showing the modified 667B transmitter in place.

Fig. 28 - The project cabinet shown from another angle showing the modified 667B transmitter in place.