

STATION DIALS

25-TYPE

IDENTIFICATION AND MAINTENANCE

1. GENERAL

1.01 This section is reissued to:

- Include procedures for field conversion of the 25-type dial from 10-button to 12-button
- Show 25A1, 25A3, 25B3, 25H4, 25K3, 25M3, and 25N3 dials MD
- Add information on 25P4, 25R3, 25W3 and 25Y3 dials.
- Add dust cover

Since this reissue covers a general revision, arrows ordinarily used to indicate changes have been omitted.

2. IDENTIFICATION

2.01 The 25-type TOUCH-TONE® dial is a transistorized multifrequency dialing device equipped with pushbuttons having numbers or numbers and letters. Earlier versions of this dial have 10 buttons only (Fig. 1 and 2). Currently manufactured dials are convertible to 12-button operation by the addition of two snap-in special service buttons (Fig. 3 and 4).

2.02 A transistorized oscillator generates the customer dialing signals and is powered by current from the telephone line.

2.03 Table A lists the 25-type dials, their application and design features.

2.04 A P-48V064 dust cover has been added to protect the rear of the dial.



Fig. 1—10-Button 25-Type Nonconvertible Dial, Front View

3. CONVERSION

SPECIAL SERVICE BUTTONS

3.01 A kit of parts consisting of two buttons, two collars, and two compression springs is necessary to convert the 25-type 10-button TOUCH-TONE dial to a 12-button dial. D-180115 Kit of Parts is used for nonilluminated dials and D-180116 Kit of Parts is used for illuminated dials.

3.02 Install special service buttons as follows:

- (1) Remove adhesive plates covering the two special service button openings in the dial face.

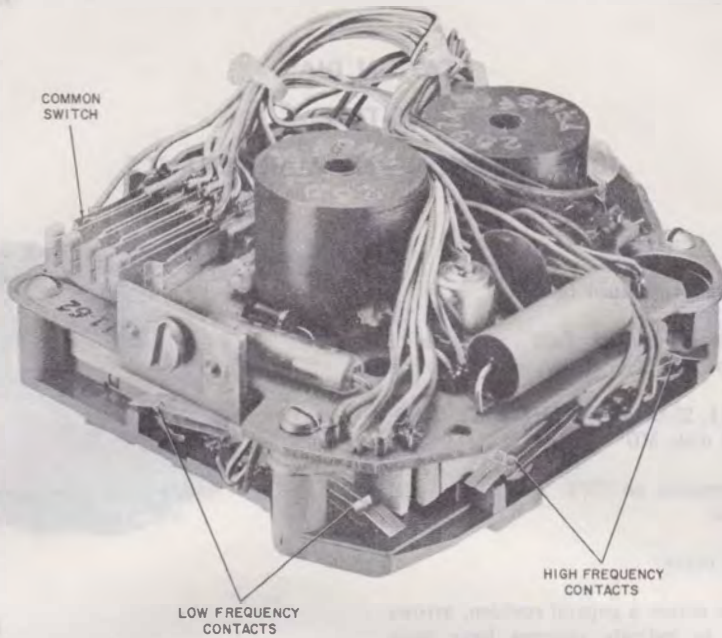

Fig. 2—25-Type Dial, Rear View

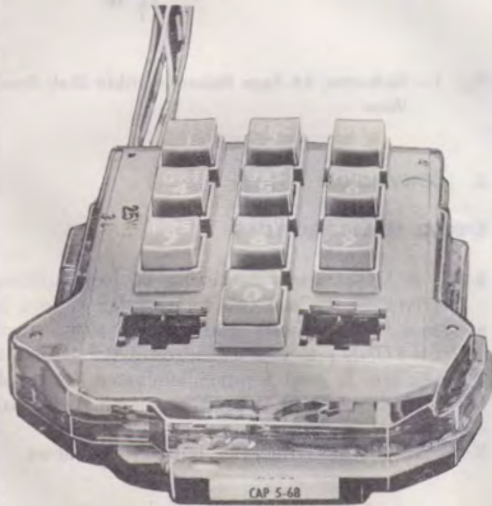

Fig. 3—10-Button 25-Type Convertible Dial with Dust Cover, Front View

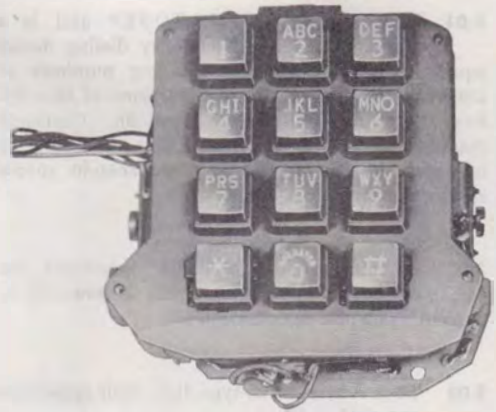

Fig. 4—Convertible 25-Type Dial with Special Service Buttons Installed

TABLE A

ORDERING GUIDE	PUSHBUTTON CHARACTERS	APPLICATION	DESIGN FEATURES
25A1 (MD)	Numbers Only	General purpose; in desk, wall, and panel mounted telephone sets	Cannot be used with 3-type Speakerphone.
25A3 (MD)	Letters and Numbers		
25B3 (MD)		In telephone sets for 3-type Speakerphone Systems	Similar to 25A3(MD) dial but has additional leads.
25D3 (MD)		Forms part of the 26B dial (MD)	Similar to 25A3(MD) dial but has additional leads for card reader.
25E3		In 1A2, 2A2, and 1235G coin telephones	Similar to 25A3(MD) dial but has modified circuit for use with coin telephones. Not convertible to 12 buttons.
25F1	Numbers only	In Data system	Similar to 25A1(MD) but has a modified circuit board, and leads for a data set.
25G1		Forms part of 26C dial	Similar to 25F1 dial but has additional leads to card reader.
25H4 (MD)	Letters and Numbers	For use in PRINCESS® telephone sets	Dial light illuminates the pushbuttons by means of a clear plastic light guide mounted within the dial.
25J3		In sets associated with 757A PBX	Additional leads provide functions necessary for use with 757A PBX. See Fig. 5.
25K3 (MD)		May be used on all switchboards	Plug ended — to mount on switchboard, a 50A dial mounting must be used.
25L3		1234G-type coin collector telephone	Similar to 25A3(MD) dial but has modified circuit for use with coin telephones. Not convertible to 12 buttons.
25M3 (MD)		Forms part of the 26D dial (MD)	Similar to 25D3(MD) but has additional leads for card reader. Replaces 25D3 dial.
25N3 (MD)		Forms part of the 26E card dialer (MD) on 557A and B PBXs	Plug-ended to mount on switchboard card dialer.
25P4		For use in PRINCESS® telephone sets	Similar to 25H4(MD) with extra leads for polarity guard and surge protector, amplified handsets, and 2- 4-wire telephone sets. Replaces 25H4 dial.
25R3		Forms part of 26F dial	Similar to 25M3(MD) with extra leads for polarity guard and surge protector, amplified handsets, and 2- 4-wire telephone sets. Replaces 25D3(MD) and 25M3 dials. See Fig. 6.
25S3		May be used on all switchboards	Plug-ended to mount on switchboard; use a 50A dial mounting. Replaces 25K3(MD) dial.
25T3		Forms part of the 26G card dialer on 557A and B PBXs	Plug-ended to mount on switchboard card dialer. Replaces 25N3(MD) dial.
25U3		For use in CALL-A-MATIC® telephone set	Spade tip leads connect to telephone circuit and plug-ended to connect to 51A CALL-A-MATIC dial.
25W3		General purpose; in desk, wall, and panel mounted telephone sets	Similar to 25A3(MD) with extra leads for polarity guard and surge protector, amplified handsets, and 2- 4-wire sets. Replaces 25A3 dial.
25Y3		In telephone set for 3-type Speakerphone Systems	Similar to 25B3(MD) with extra leads for polarity guard and surge protector, amplified handsets, and 2- 4-wire telephone sets. Replaces 25B3 dial.

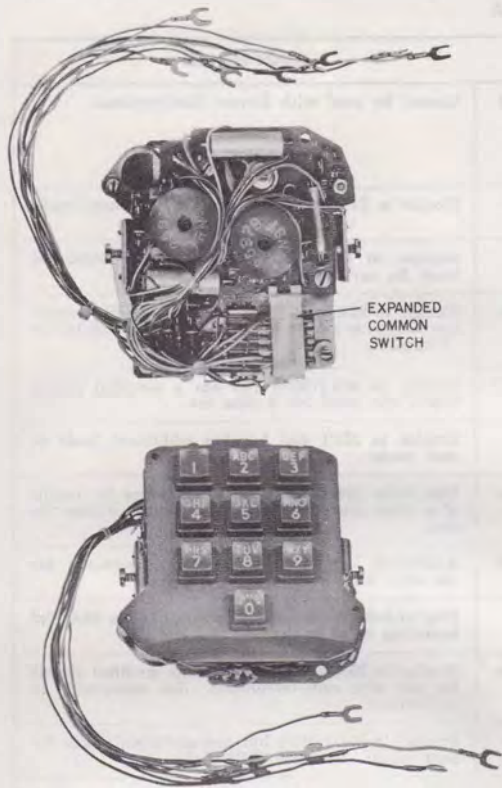

Fig. 5—25J3 Dial

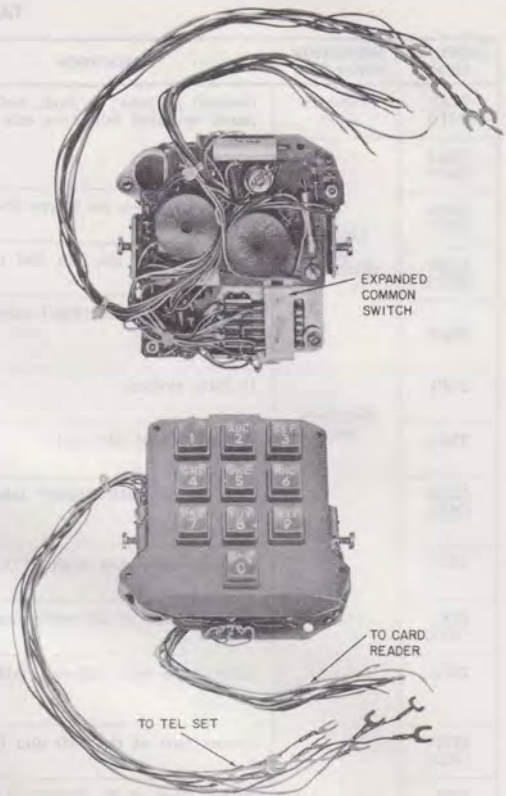

Fig. 6—25R3 Dial

(2) Assemble a button and collar by slipping the collar over the gray end of the button so that the tangs of the collar point toward the white end of the button. The collar and button must be assembled in the relative positions shown in Fig. 7. The tab on the button should be on the right side when looking at the face of the button.

(3) Insert spring into hole in back of button.

(4) Hold the button, collar, and spring assembly between the thumb and forefinger and insert the assembly, spring first, straight into the dial cover plate cavity making sure the two tabs extending from the collar fit into the two recesses at the top and left sides of the cavity. The assembly must be inserted far enough so that the tangs on the collar snap and lock around the projections in the sides of the dial cover plate cavities to hold the button assembly firmly.

(5) The * button should be installed on the left side of the dial and the # button on the right side of the dial (Fig. 7).



Exercise care in handling button, collar, and spring assembly to prevent losing spring.

3.03 Remove special service buttons by inserting a KS-16750, List 2 releaser between the

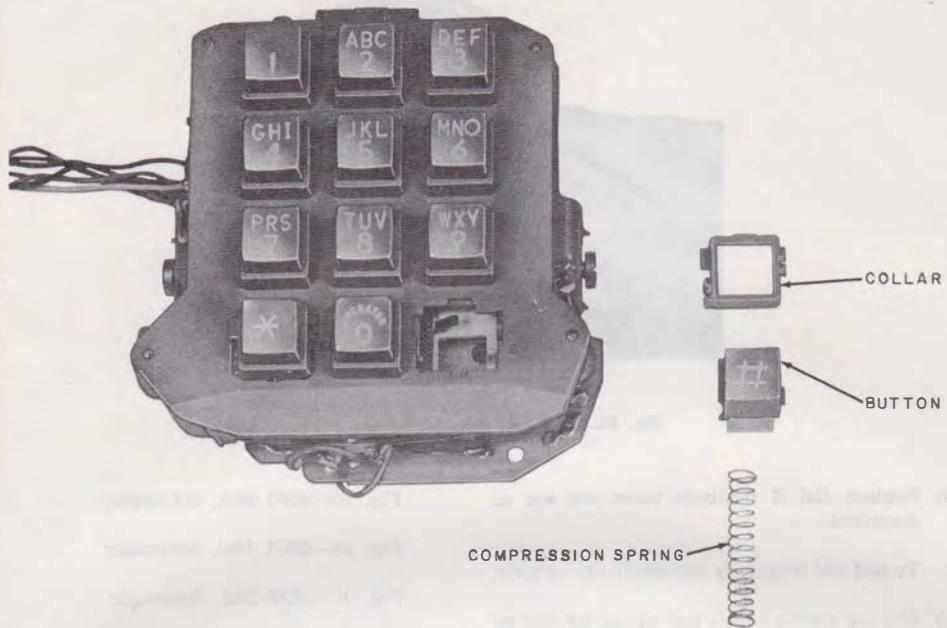

Fig. 7—25W3 Dial with Special Service Button Disassembled

two tangs located on each side of the button assembly, starting on the side toward the "O" button first as shown in Fig. 8. Pry the assembly gently upwards exercising caution to prevent the compression spring from causing the button and collar to fly outward when released. Do not reuse the collar.

4. MAINTENANCE



Maintenance of 25-type dial consists only of determining if the dial is inoperative. Do not attempt adjustments of the dial in the field.

4.01 Check polarity of dial before testing. The 25-type dial will function only when the (O-BK) lead is connected to the negative (ring) side of the circuit and the (G) lead is connected to the positive (tip) side of the circuit.

4.02 If unable to dial, proceed as follows:

- (1) Check wiring for secure and correct connections.
- (2) Check for presence of dial tone. If no dial tone is heard, make a check with the 1011B test set at the connecting block. If dial tone is heard at the connecting block, make normal test of telephone set components as described in appropriate sections.
- (3) Break dial tone by dialing a digit as prescribed by local instructions. If unable to break dial tone, restore switch hook to normal and connect 1011B test set across telephone set incoming line terminations. Dial the appropriate digit on test set to break dial tone. If dial tone can be broken, replace the dial.
- (4) Check all buttons for tone feedback. When any button is depressed, two tones, blended together but identifiable as two tones, should be heard in the receiver.



Fig. 8—Removing Special Service Button

- (5) Replace dial if feedback tones are not as described.

4.03 To test dial frequency and amplitude outputs:

- (1) Dial the station ringer test circuit for testing TOUCH-TONE dials. Refer to appropriate Section in Division 951 for details.
- (2) Replace dial if it fails to meet the above requirements.

5. SCHEMATIC INDEX

Fig. 9—25A1 Dial (MD), Schematic

Fig. 10—25A3 and 25H4 Dials (MD), Schematic

Fig. 11—25B3 and 25M3 Dials (MD), Schematic

Fig. 12—25E3 Dial, Schematic

Fig. 13—25F1 Dial, Schematic

Fig. 14—25G1 Dial, Schematic

Fig. 15—25J3 Dial, Schematic

Fig. 16—25K3 and 25N3 Dials (MD), Schematic

Fig. 17—25L3 Dial, Schematic

Fig. 18—25P4 and 25W3 Dials, Schematic

Fig. 19—25R3 and 25Y3 Dials, Schematic

Fig. 20—25S3 Dial, Schematic

Fig. 21—25T3 Dial, Schematic

Fig. 22—25U3 Dial, Schematic

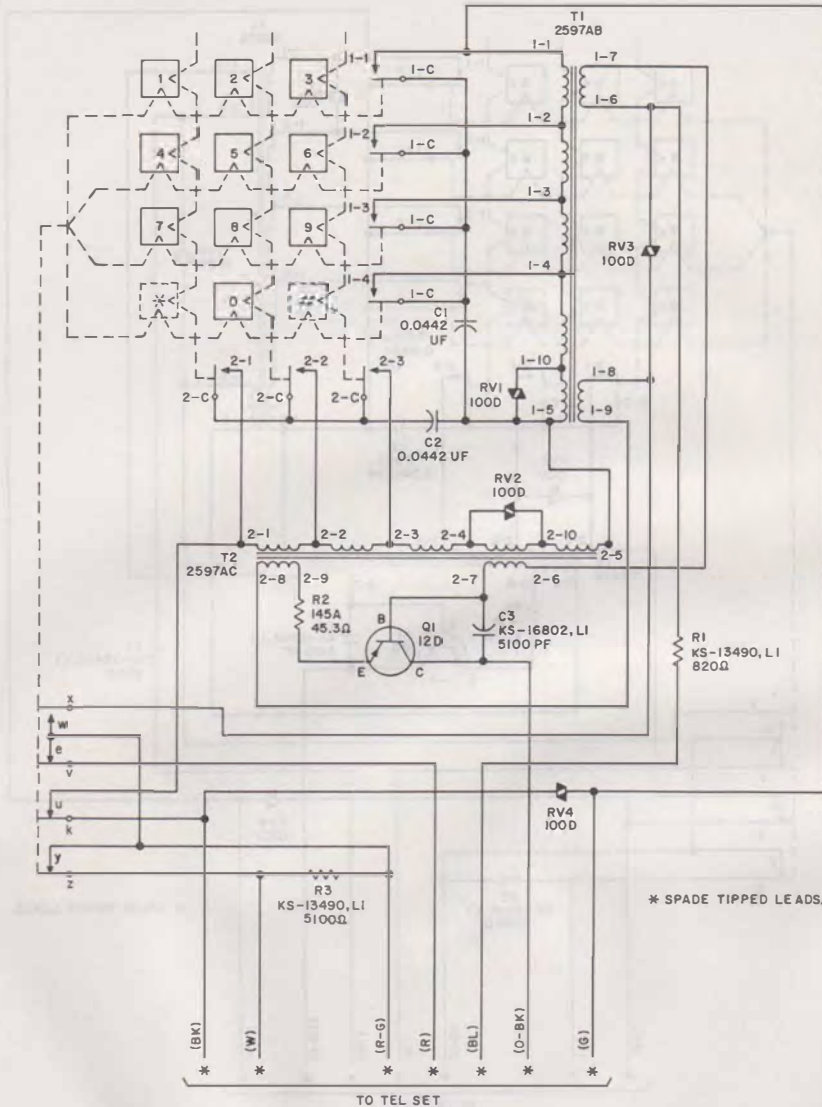

Fig. 9—25A1 Dial (MD), Schematic

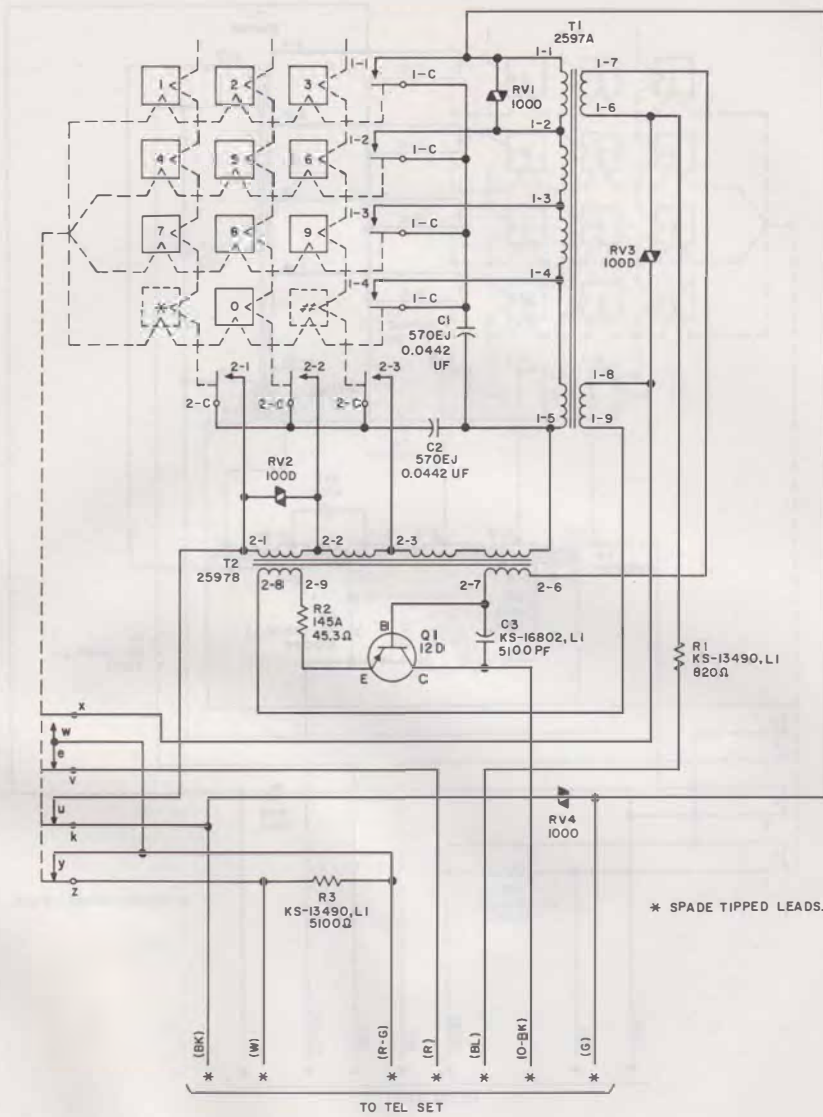

Fig. 10—25A3 and 25H4 Dials (MD), Schematic

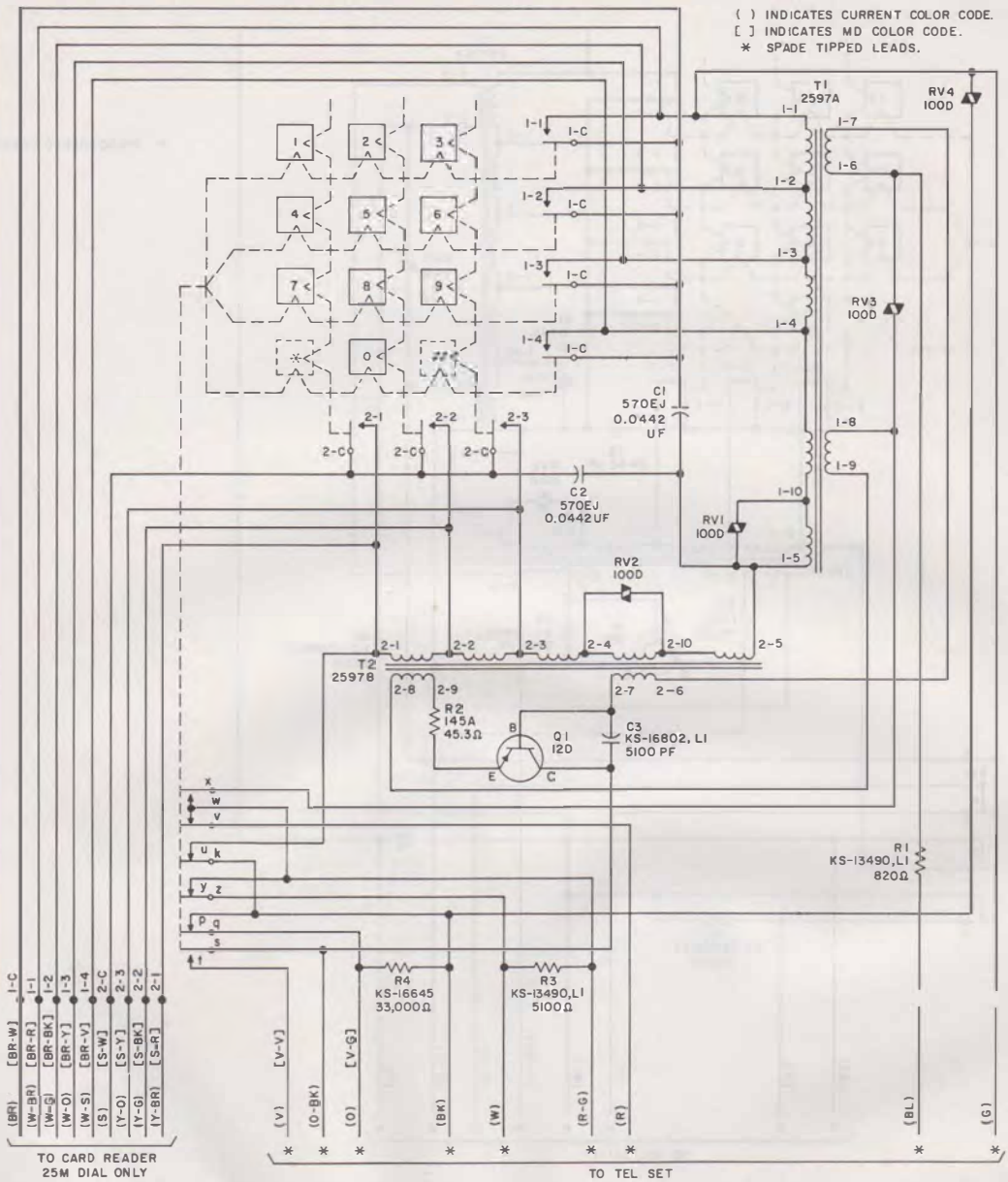

Fig. 11—25B3 and 25M3 Dials (MD), Schematic

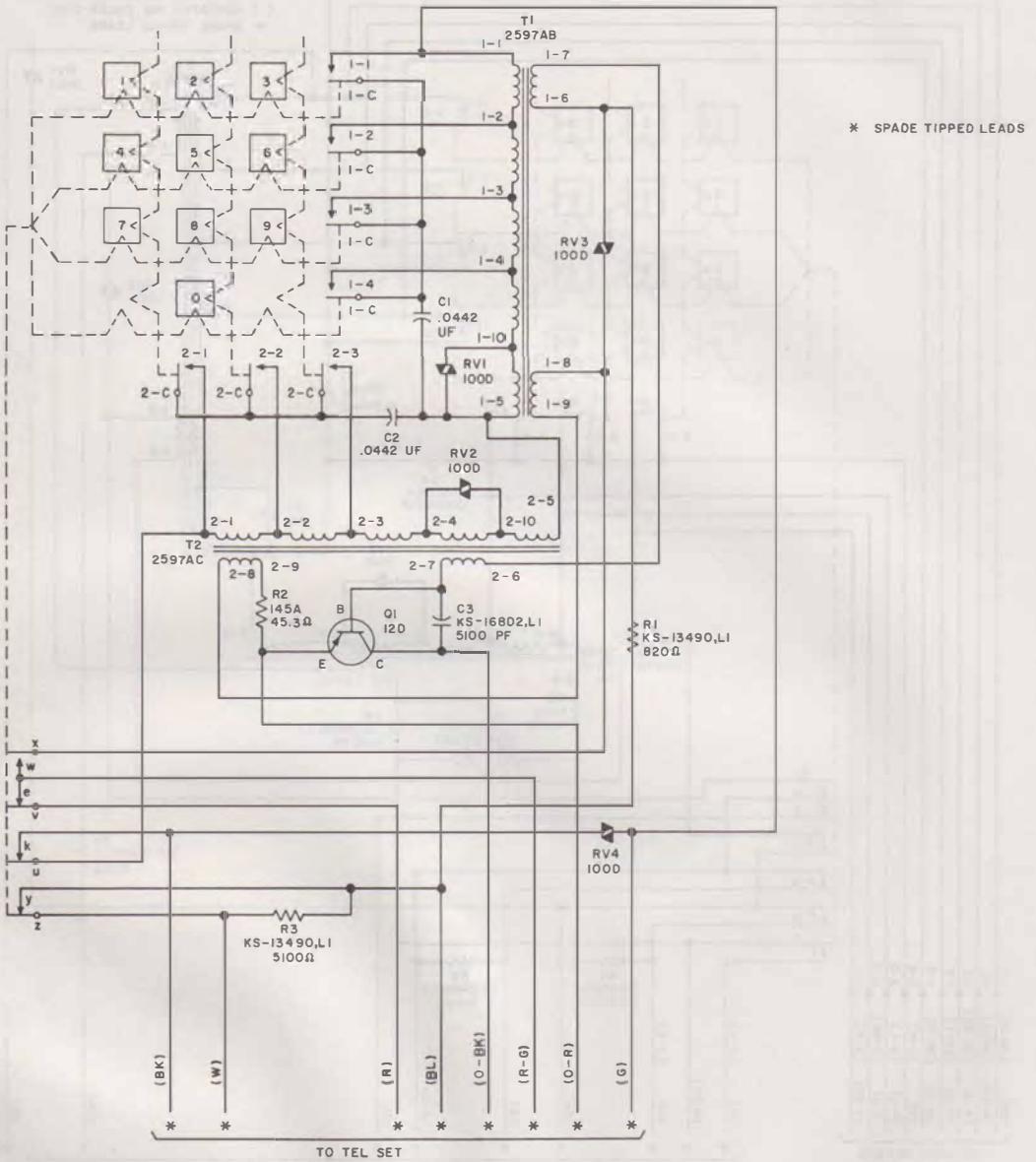

Fig. 12—25E3 Dial, Schematic

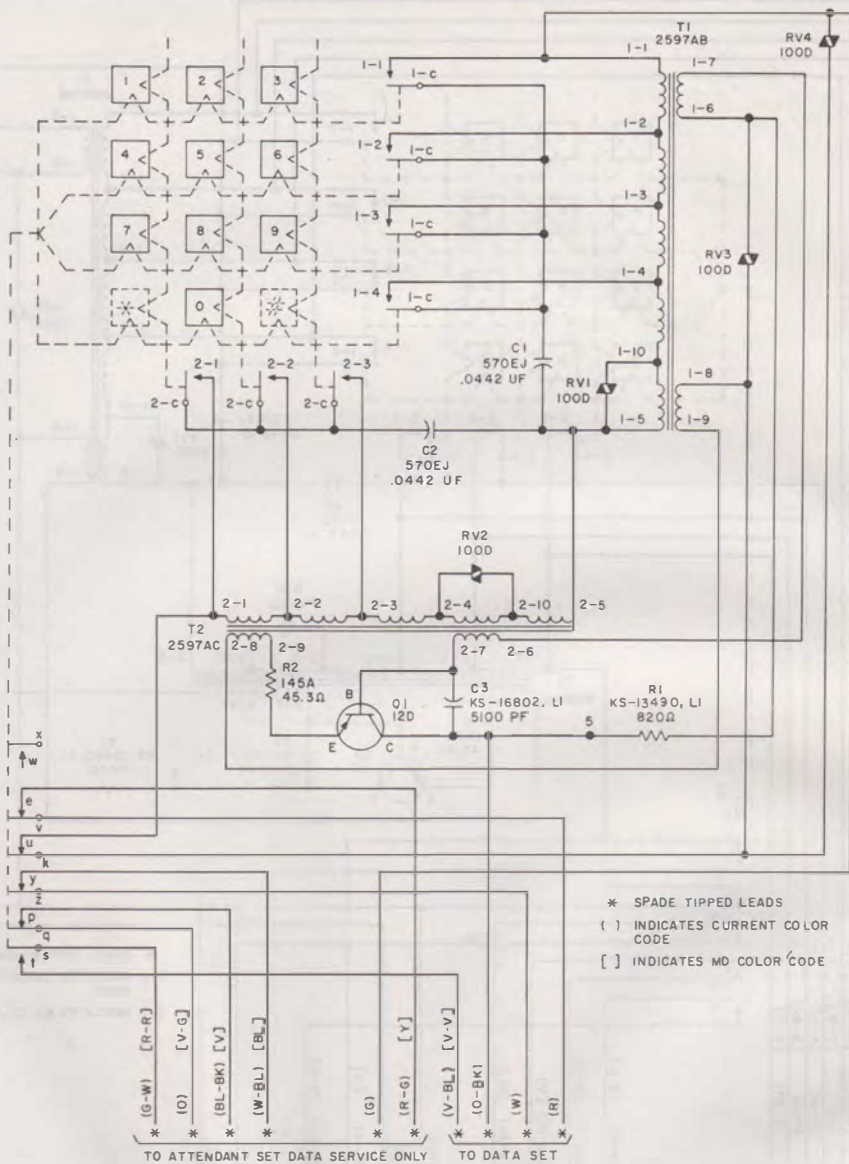

Fig. 13—25F1 Dial, Schematic

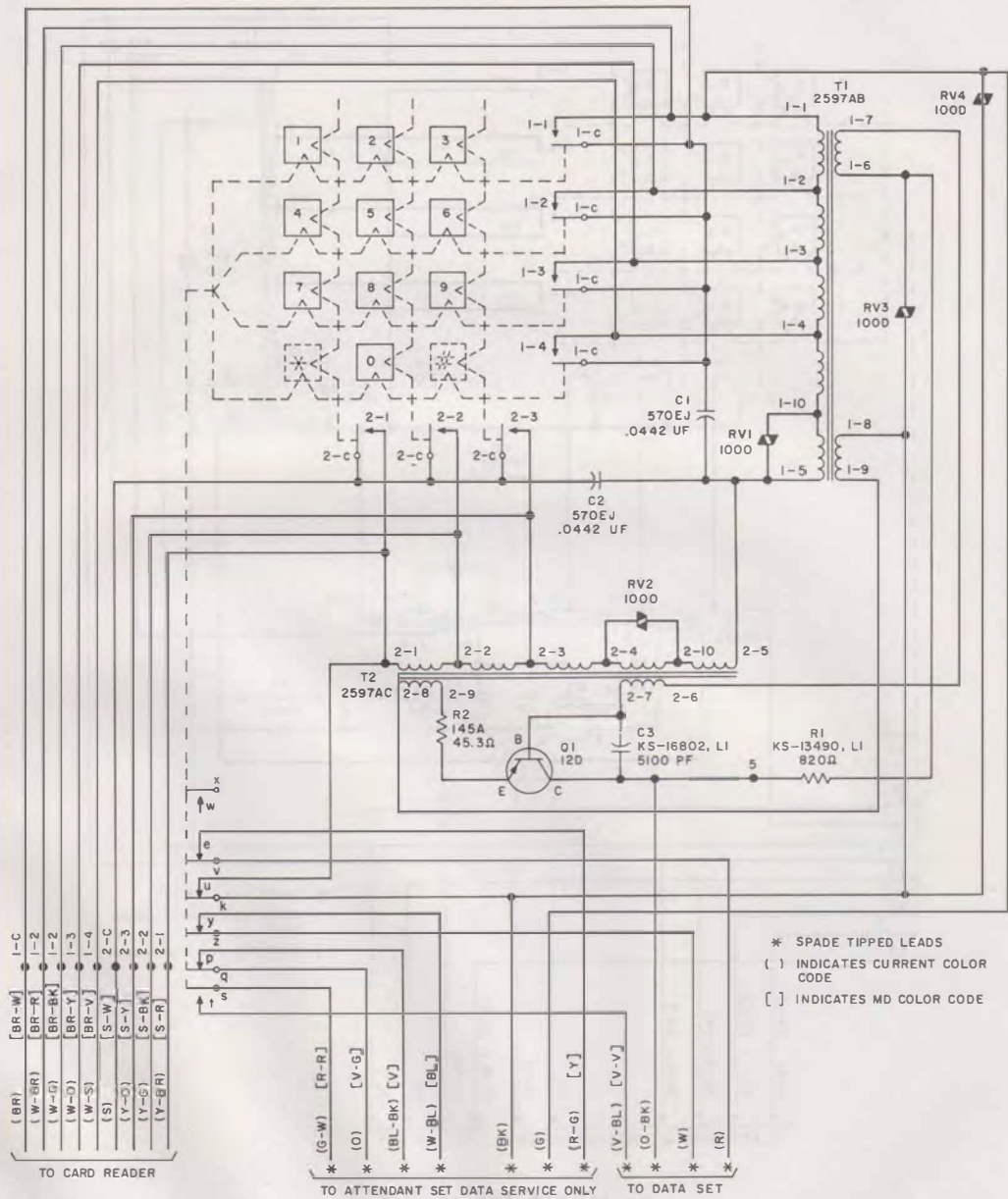

Fig. 14—25G1 Dial, Schematic

- () INDICATES CURRENT COLOR CODE
- [] INDICATES MD COLOR CODE
- * SPADE TIPPED LEADS

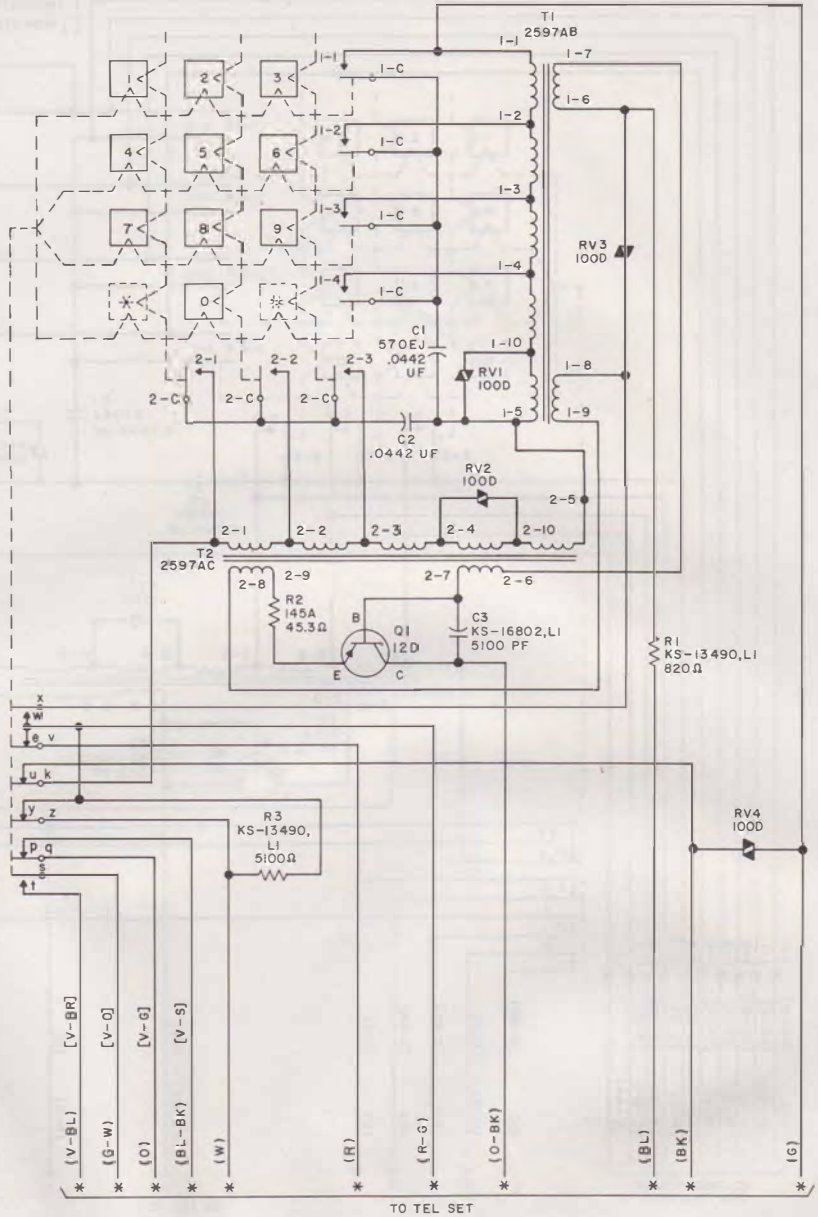

Fig. 15—25J3 Dial, Schematic

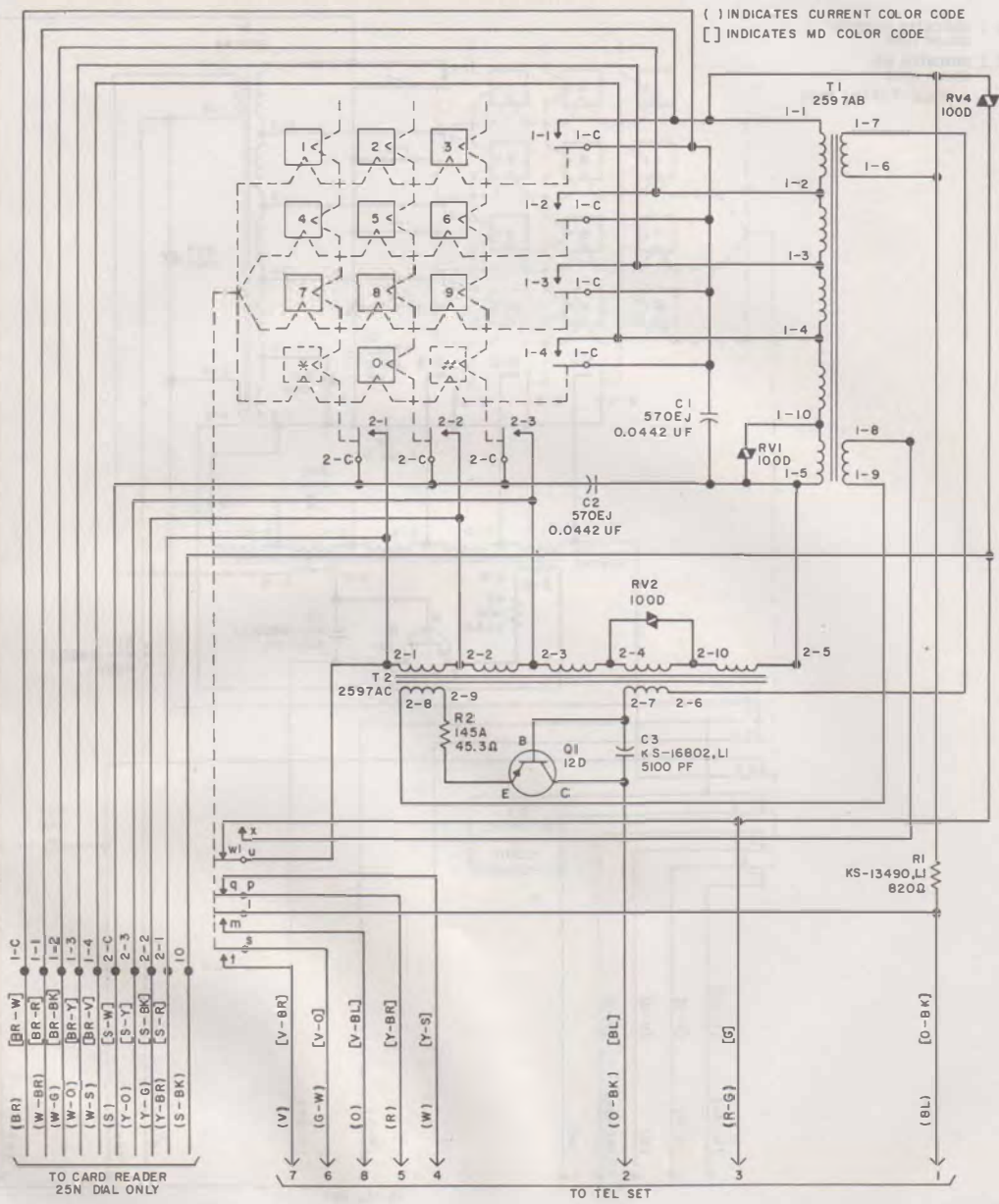

Fig. 16—25K3 and 25N3 Dials (MD) Schematic

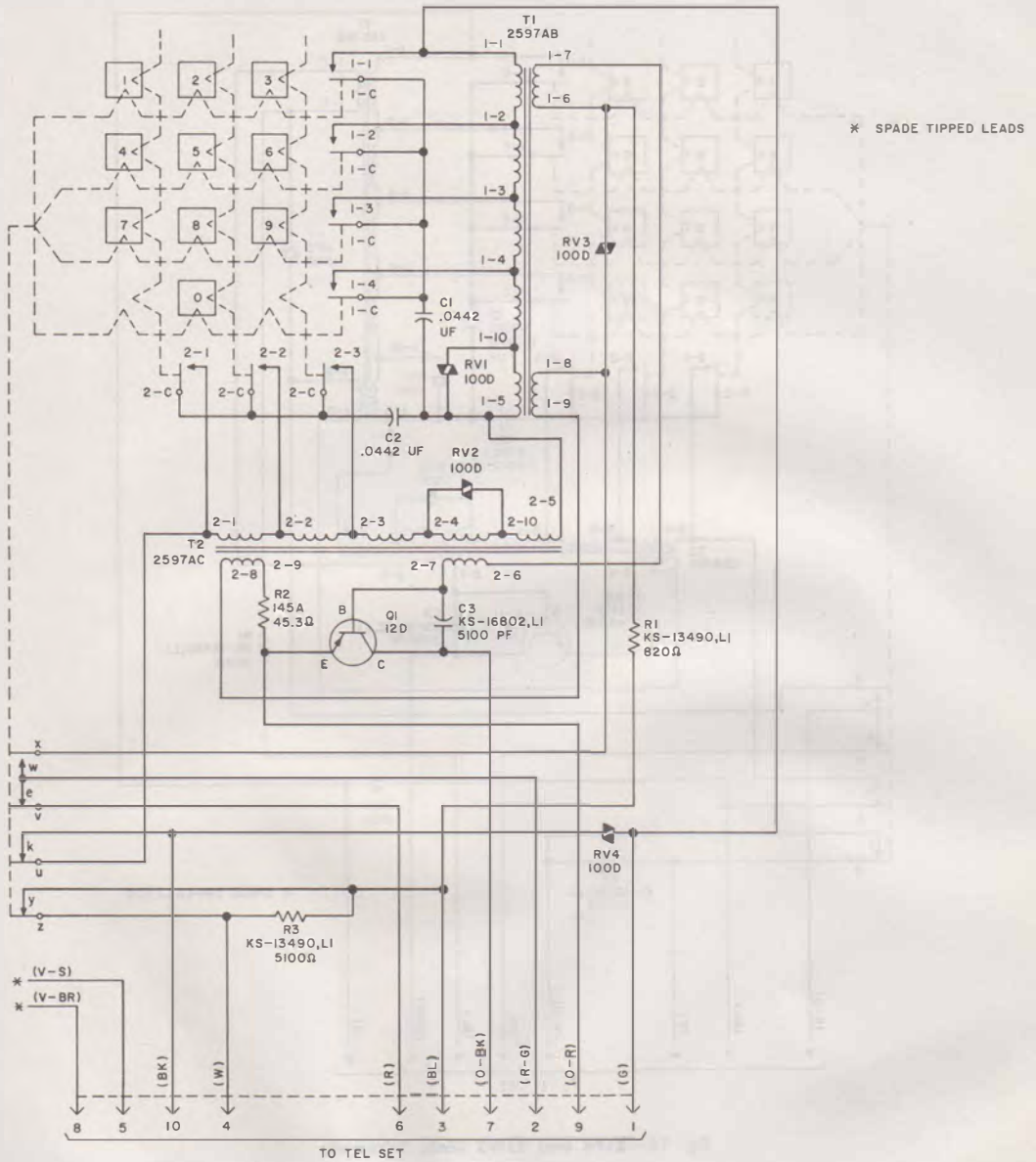

Fig. 17—2513 Dial, Schematic

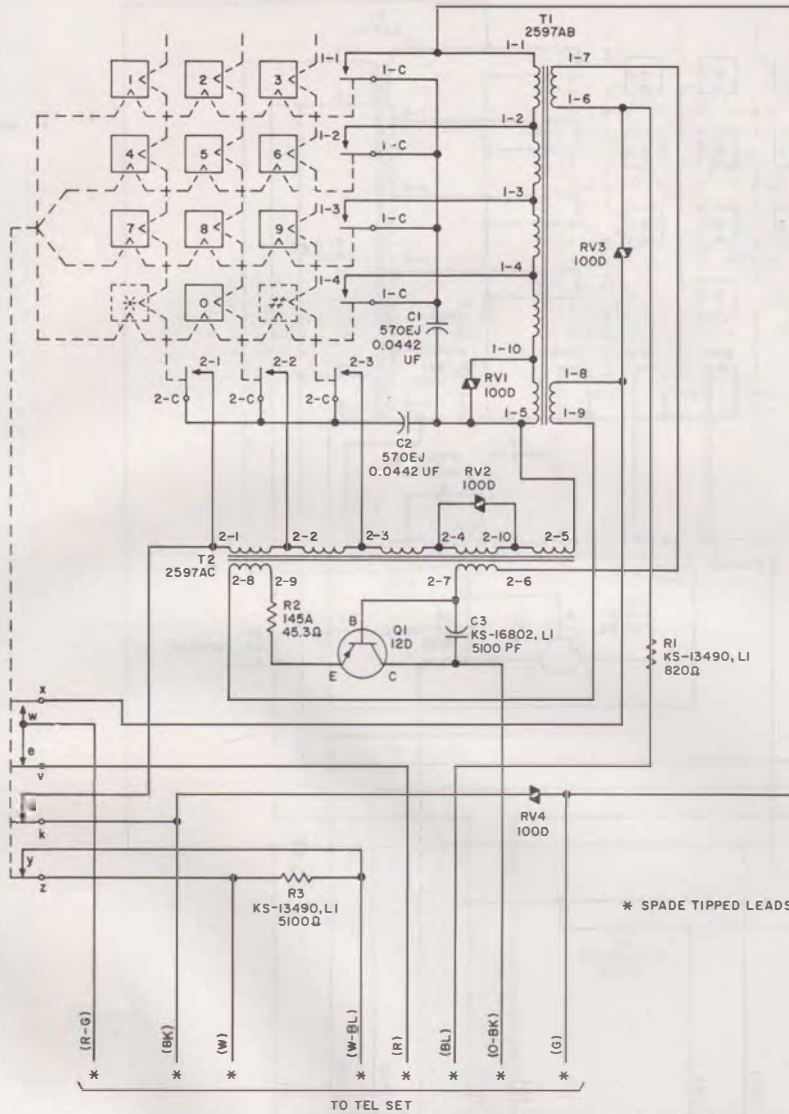

Fig. 18—25P4 and 25W3 Dials, Schematic

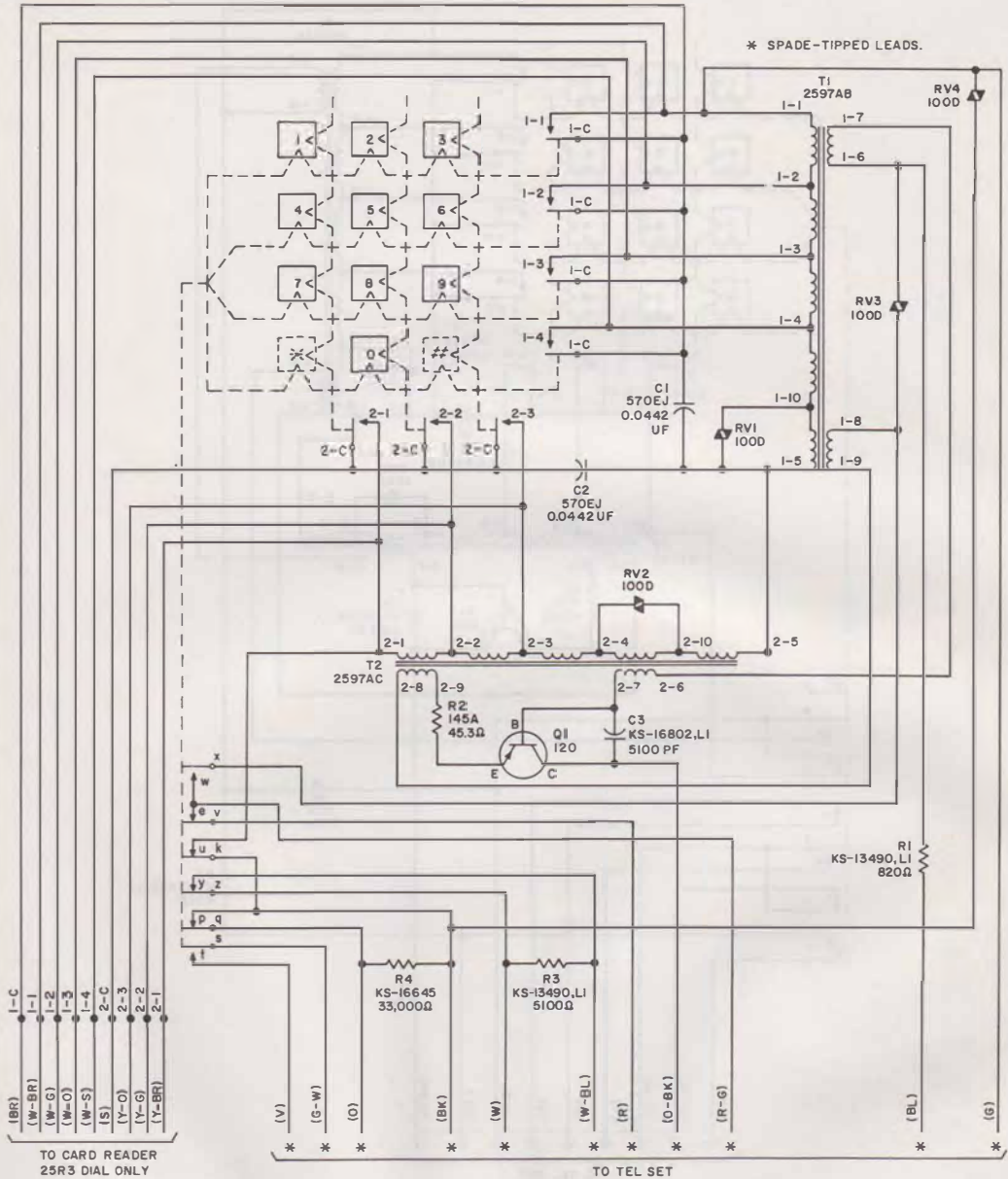

Fig. 19—25R3 and 25Y3 Dials, Schematic

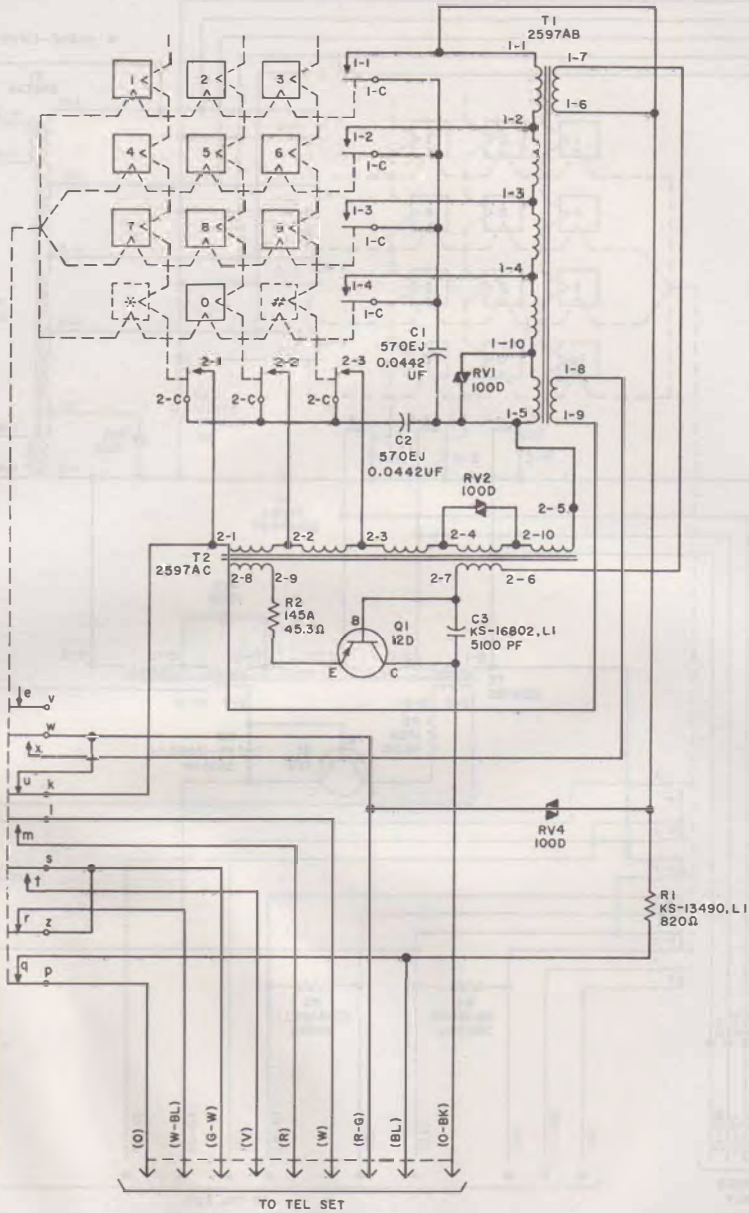

Fig. 20—2553 Dial, Schematic

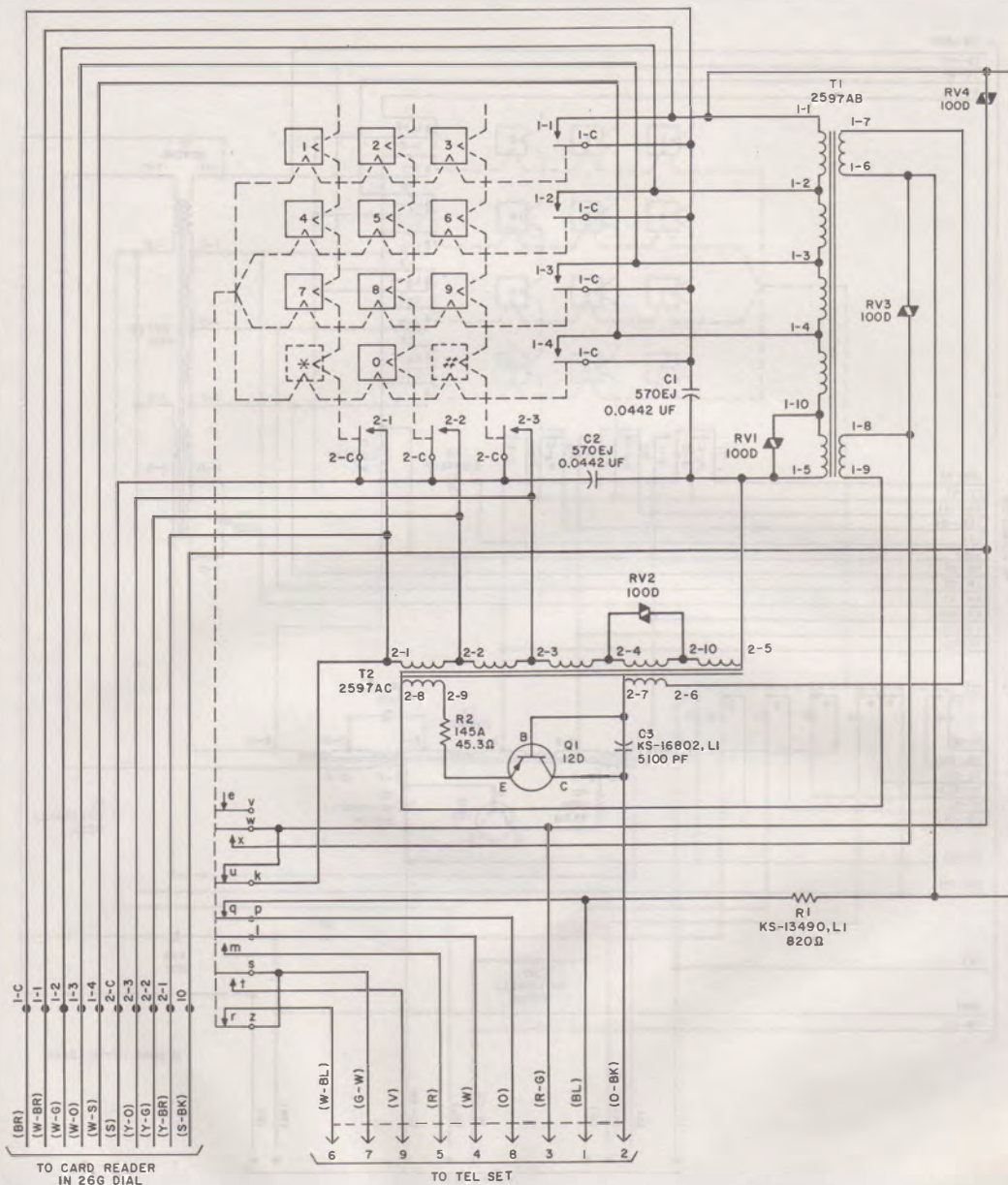

Fig. 21—25T3 Dial, Schematic

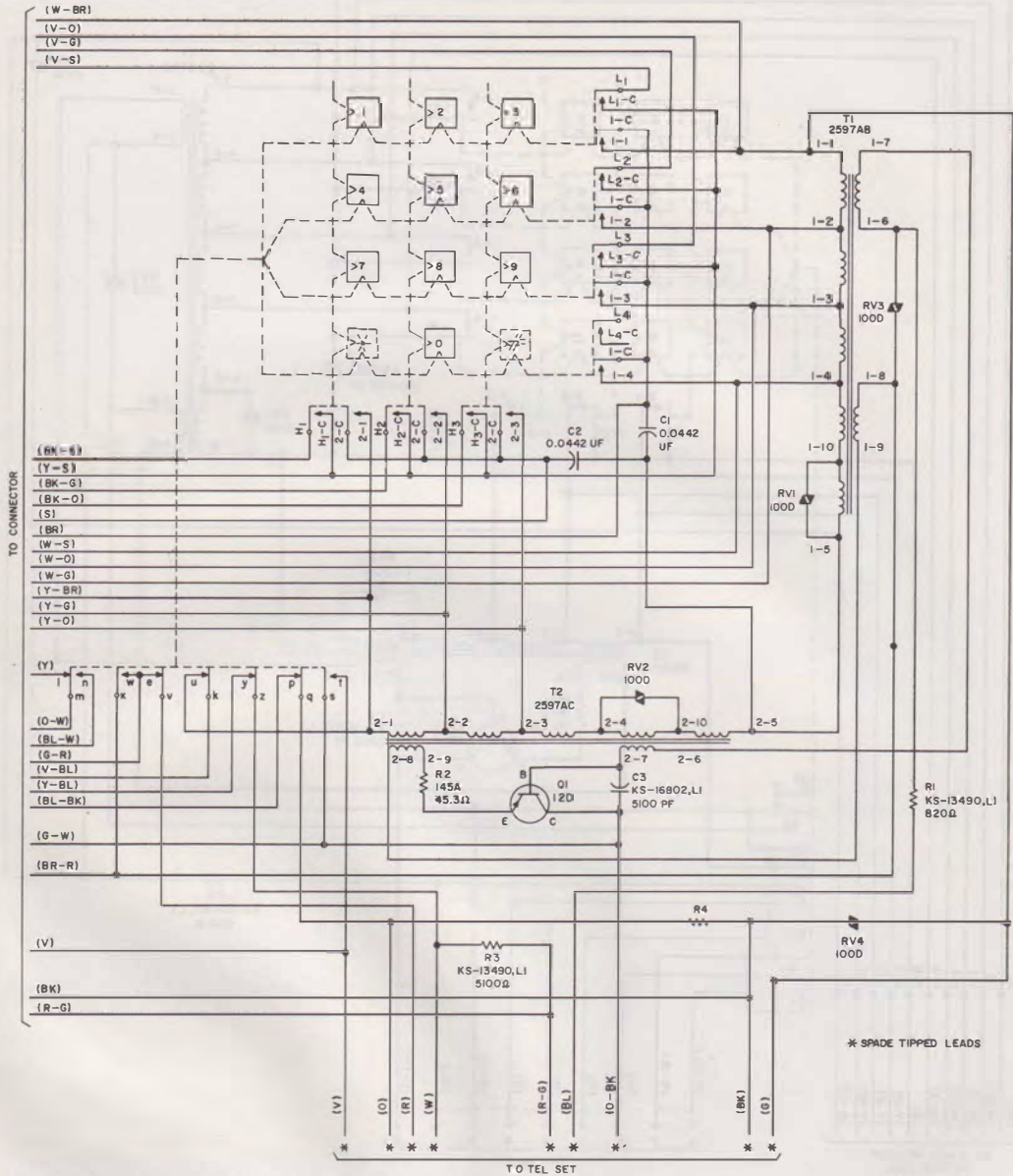

Fig. 22-25U3 Dial, Schematic