

JACKS AND PLUGS SERVICE

1. GENERAL

1.01 Reissued to:

- Include the 625A, 625B, 625C, and 625F jacks
- Include information on KS-20502, List 2 bracket which replaces the KS-20502, List 1 (MD) bracket
- Include the 224A and 225A adapters.

1.02 Do not use hand telephone sets (those requiring a subscriber set) and telephone sets together in the same jack and plug system.

1.03 Mount jacks in a uniform manner so that when the plug is inserted, the set mounting cord enters the bottom of the plug.

1.04 Telephone sets should be kept indoors when not in use. Advise the customer of the importance of protecting a telephone set from inclement weather in order to maintain good telephone service.

1.05 Wiring variations (eg, class-of-service, etc, normally made in the connecting block) should be made in the plugs or inside modular telephone sets. Do not make wiring variations in the station jacks. When required, two spade tips may be placed under one screw head. In some plugs, eg, 505A, there are two socket-type connectors on each terminal pin. These extra terminal connectors may be used to bridge spade tip conductors. If the extra connectors are used to store unused cord conductors, the unused conductors must be disconnected and insulated at the telephone set end.

2. JACKS AND JACK MOUNTINGS—INDOOR

2.01 Only one conductor shall be connected to a single clip of a clip-type jack terminal. The loop-through method for terminating IW cable may be used on jacks which have dual clip-type terminals.

2.02 Connect conductors as indicated by the color designators stamped next to the terminals. The red conductor is terminated at the R terminal, etc. Table A shows the connections for 4-conductor jacks.

TABLE A
CONNECTIONS TO 4-PIN JACKS

INSIDE WIRE	4-PIN JACK
(G) Tip	G
(R) Ring	R
(Y) Ground* and/or Transformer	Y
(B) Transformer	B

*Ground may be omitted if not required for service.

2.03 Table B shows the connections for 8- and 12-conductor jacks.

Caution: Test each jack location for correct circuit operation.

Installation of Nonflush Jacks

392A Jack

2.04 Install as follows:

- (1) Connect cable conductors to jack.
- (2) Fasten base assembly to mounting surface with 3/4-inch No. 8 PH or FH cadmium plated tapping screws.
- (3) Fasten cover base assembly with furnished machine screws taking care not to pinch wiring.

TABLE B

8- AND 12-CONDUCTOR JACKS – CONNECTIONS

INSIDE WIRE QUAD		D AND E INSIDE WIRING CABLE	NO. TERMINALS	
			8	12
		TERMINAL DESIGNATIONS		
1st	Red	BL-W	R	1
	Green	W-BL	G	2
	Yellow	O-W	Y	3
	Black	W-O	BK	4
2nd	Red	G-W	W	5
	Green	W-G	R-R	6
	Yellow	BR-W	Y-Y	7
	Black	W-BR	BK-BK	8
3rd	Red	S-W		9
	Green	W-S		10
	Yellow	BL-R		11
	Black	R-BL		12

404B (MD) and 549A Jacks**2.05** Install as follows:

- (1) Connect station wire to jack and dress wiring inside shell.
- (2) Fasten jack to mounting surface with furnished screws.

551A Jack**2.06** Install as follows:

- (1) Connect station wire or cable conductors to clip terminals of jack using 714-type tool. Conductors may be loop-through terminated.
- (2) Fasten jack to mounting surface with furnished screws.

Installation of Flush-Type Jacks In Standard Electrical Outlet Boxes**391A Jack****2.07** The 391A jack is mounted in standard electrical outlet box as follows:

- (1) Connect station wire to jack and dress.

- (2) Mount jack in outlet box and fasten faceplate on jack using furnished screws.

497A (MD) Jack**2.08** The 497A (MD) jack is mounted in standard electrical outlet box as follows:

- (1) Mount 493A jack on 43A bracket.
- (2) Connect station wire to jack.
- (3) Mount jack equipped bracket in outlet box.
- (4) Fasten faceplate with furnished screws.

547A (MD) or 547B Jack**2.09** Install as follows:

- (1) Attach 541A jack on 74A (MD) bracket or 43B bracket.
- (2) Connect station wire or cable to jack.
- (3) Mount jack and bracket assembly in outlet box.
- (4) Install faceplate. (The cover must be on jack before placing faceplate.)

493A (MD) or 548A Jack**2.10** Install as follows:

- (1) Attach jack to 43-type bracket (Fig. 1).
- (2) Connect station wire or cable to jack.
- (3) Attach bracket to outlet box and install suitable faceplate.

550A Jack

2.11 The 550A jack is assembled in the same manner as the 497A (MD) jack. It consists of a 548A jack, 43A or 43B bracket, faceplate, and mounting screws.

Installation of Flush-Type Jacks In 63A or KS-20502-Type Bracket

- 2.12** The 493A (MD), 541A, and 548A jacks can be mounted on a 63A or KS-20502-type

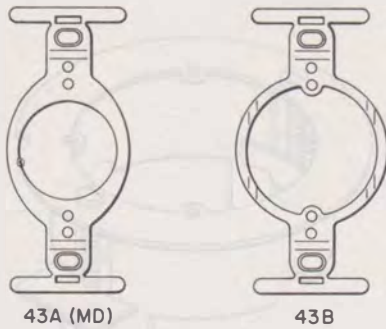

- TO MOUNT JACKS IN STANDARD ELECTRICAL OUTLET BOX
- BREAK-OFF WINGS

- REPLACED BY 43B BRACKET
- TO MOUNT 493A JACK (MD) 548A JACK
- COMPONENT OF 497A JACK (MD) 550A JACK (OLD)
- TO MOUNT 493A JACK (MD) 541A JACK 548A JACK 625F JACK
- REPLACES 43A BRACKET (MD) 74A BRACKET (MD)
- COMPONENT OF 547B JACK 550A JACK 625B JACK

Fig. 1—43-Type Bracket

bracket (Fig. 2 and 3) with a 16-type faceplate. Use the same color faceplate as the jack.

2.13 When mounting jacks on the 63A bracket, the 16-type faceplate ring retainer is required. The 16-type faceplate can be mounted to the KS-20502-type bracket without ring retainer.

- (a) The 493A (MD) or 548A jack is installed on the 63A bracket as follows:
- (1) Mount the ring retainer on bracket.
 - (2) Connect station wire to jack.
 - (3) Mount jack on ring retainer.
 - (4) Mount faceplate on ring retainer.



- USE TO PREWIRE BUILDING DURING CONSTRUCTION
- MOUNTED TO STUDDING
- USE WITH 16-TYPE FACEPLATE
- FOR MOUNTING 493A JACK (MD) 541A JACK 548A JACK 625F JACK

Fig. 2—63A Bracket

(b) The 493A (MD) or 548A jack is installed on the KS-20502-type bracket as follows:

- (1) Connect station wire to jack.
- (2) Mount jack on bracket using screws supplied with bracket.
- (3) Mount faceplate to bracket using screws supplied with bracket.

◆KS-20502-Type Bracket

2.14 The KS-20502, List 2 plastic bracket (Fig. 3) is a replacement for the KS-19407, List 1 (MD) steel bracket (Fig. 4) and the KS-20502, List 1 (MD) plastic bracket (Fig. 5). This bracket is

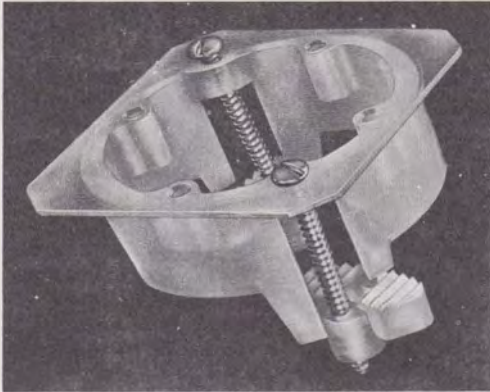

- PLASTIC BRACKET, REPLACEMENT FOR STEEL KS-19407 LI BRACKET AND PLASTIC KS-20502 LI BRACKET.
- USE TO PREWIRE BUILDING DURING CONSTRUCTION.
- FOR MOUNTING 541A, 548A OR 625F JACK AND 16-TYPE FACEPLATE.
- WALL HOLE 2-1/4 IN. DIAMETER.
- WALL THICKNESS LIMIT 1-1/4 IN.

Fig. 3—KS-20502, List 2 Bracket

intended to mount on 541A or 548A jack and 16-type faceplate.♦

2.15 It may be installed in a 2-1/4 inch diameter hole with a wall thickness of 1-1/4 in. max. as follows:

- (1) Fasten bracket in wall opening by first placing the self-aligning clamps behind interwall material and tightening the two screws.
- (2) Bring concealed building wire through opening of bracket and make connections to 541A or 548A jack.
- (3) Position jack and faceplate on bracket so two screw holes opposite each other align. Fasten jack and faceplate to bracket using two screws furnished with bracket. These are special thread cutting screws. The use of any other

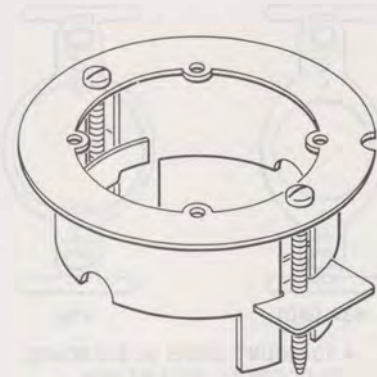

- USE FOR EXISTING WALLS
- WALL HOLE 2-1/4 IN. DIA
- WALL THICKNESS LIMIT 1-1/4 IN

Fig. 4—KS-19407, List 1 (MD) Bracket

screws could overstress the polycarbonate bracket and seriously affect its life.

541A Jack

2.16 The 541A jack is installed in the 63A bracket as follows:

- (1) Mount ring retainer on 63A bracket.
- (2) Connect station wire or cable leads to clip terminals of jack.
- (3) Mount jack on ring retainer.
- (4) Place cover on jack.
- (5) Mount faceplate on retainer ring.

2.17 The 541A jack is installed in the KS-20502 type bracket as follows:

- (1) Connect station wire or cable leads to clip terminals of jack.
- (2) Place cover on jack.
- (3) Position faceplate over cover and fasten faceplate and jack to bracket.



- PLASTIC BRACKET, REPLACEMENT FOR STEEL KS-19407 LI BRACKET
- USE TO PREWIRE BUILDING DURING CONSTRUCTION
- FOR MOUNTING 541A OR 548A JACK AND 16-TYPE FACEPLATE
- WALL HOLE 2-1/4 IN. DIAMETER
- WALL THICKNESS LIMIT 1-1/4 IN.

Fig. 5—KS-20502, List 1 (MD) Bracket

625-Type Jacks

2.18 These jacks provide a termination for the D4BU plug-ended mounting cord, used with modular telephone sets, as follows:

(a) The 625A jack (Fig. 6) replaces the 42A connecting block and the 549A jack. Dress leads as shown in Fig. 6. The 625C jack is the same as the 625A without the 42A connecting block and is used where there is an existing 42A connecting block.

(b) The 625F jack (Fig. 7) is used in new installations requiring a flush type jack or for replacement of 548A jacks. Install in same manner as the 548A jack.

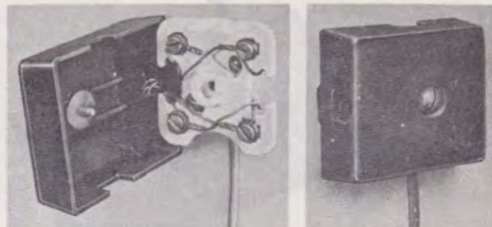
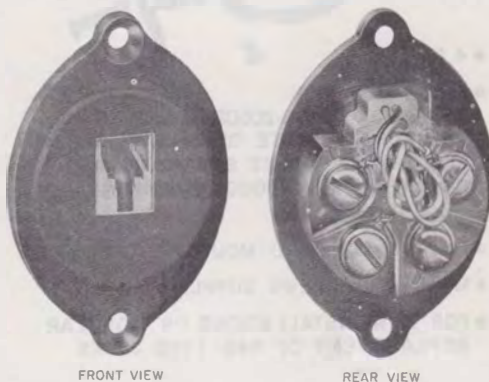

Fig. 6—625A Jack



FRONT VIEW

REAR VIEW

- 4 CONTACTS
- FLUSH MOUNTED:
USING 63A OR KS-20502, L2 BRACKET AND 16A FACEPLATE OR IN STANDARD ELECTRICAL OUTLET BOX USING 43B BRACKET OR IN WOODWORK USING 1-1/4 INCH HOLE
- MATES WITH D4BU MOUNTING CORD PLUG
- MOUNTING SCREWS SUPPLIED
- FOR NEW INSTALLATIONS OR MODULAR REPLACEMENT OF 548-TYPE JACKS

Fig. 7—625F Jack

(c) The 625B jack assembly (Fig. 8) includes the 625F jack, 43B bracket faceplate, and six screws.

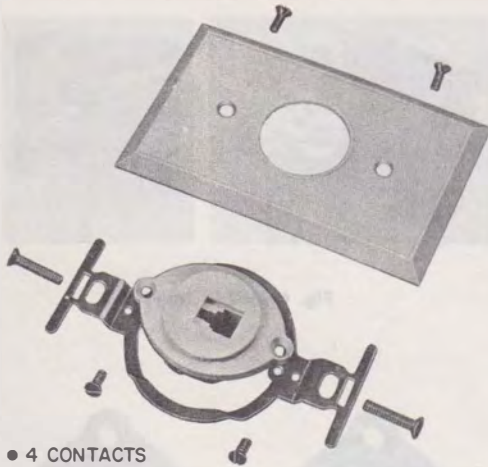

- 4 CONTACTS
- FLUSH MOUNTED:
USING 63A OR KS-20502,L2 BRACKET
AND 16A FACEPLATE OR IN STANDARD
ELECTRICAL OUTLET BOX USING 43B
BRACKET OR IN WOODWORK USING
1-1/4 INCH HOLE.
- MATES WITH D4BU MOUNTING CORD PLUG
- MOUNTING SCREWS SUPPLIED
- FOR NEW INSTALLATIONS OR MODULAR
REPLACEMENT OF 548-TYPE JACKS

Fig. 8—625B Jack Assembly

Adapters

2.19 Adapters are intended for use where it is not desirable to replace existing jacks.

(a) The 224A adapter (Fig. 9) is used to adapt the D4BU mounting cord to the 541A and 551A jacks (12-pin jack).

(b) The 225A adapter (Fig. 10) is used to adapt the D4BU mounting cord to 404B (MD), 493A (MD), 497A (MD), 548A, and 549A jacks (4-pin jack).

2.20 Where portable telephone service is required, 541A, 551A, 548A and 549A jacks should not be mixed with 625-type jacks.

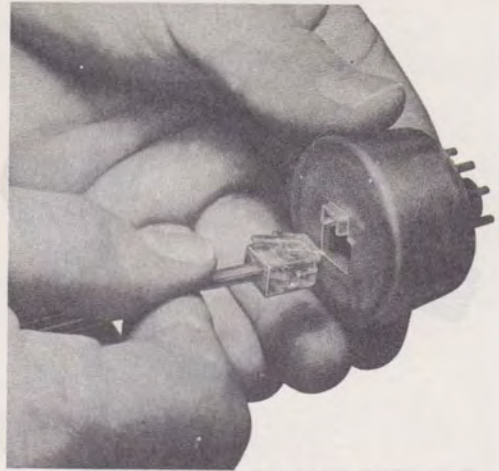

Fig. 9—224A Adapter

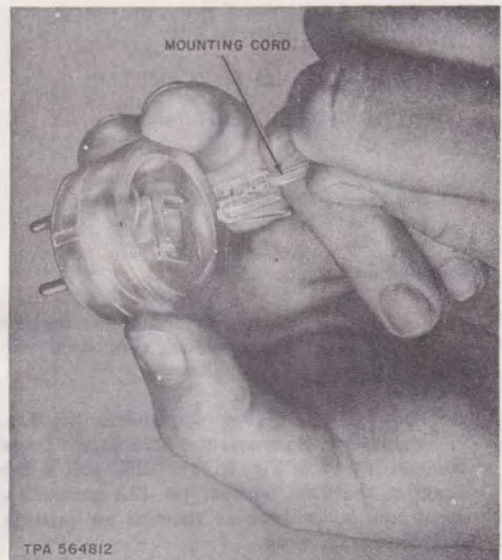

Fig. 10—225A Adapter

3. JACKS AND JACK MOUNTINGS—OUTDOOR

3.01 For a 4-conductor jack, connect conductor as indicated by the color designator stamped next to the terminals. The red conductor is terminated at the R terminal, etc.

KS-8420 Jack

3.02 Install as follows:

- (1) Arrange for a 2-11/16 inch hole at location selected for jack installation.
- (2) Temporarily insert jack in hole and mark fastener holes.
- (3) Remove jack and drill fastener holes.
- (4) Connect wire as shown in Fig. 11.
- (5) Secure jack to mounting surface with four No. 8 PH or FH cadmium plated tapping screws.

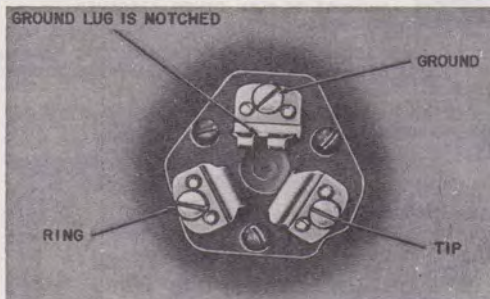

Fig. 11—Connections for KS-8420 and KS-8421 Jacks

KS-8421 Jack

3.03 Install as follows:

- (1) Arrange drop wire or bridle wire and conduit at location selected for installation (Fig. 12).
- (2) Secure the jack housing to the mounting surface using suitable fasteners.

(3) Connect wire to terminal block as shown in Fig. 11.

(4) Mount terminal block to jack housing.

(5) Install cover on housing.

KS-16151, List 1 (MD) Jack

3.04 Install as follows:

- (1) Arrange drop wire at location selected for installation.
- (2) Hold housing to mounting surface and mark fastener holes.
- (3) Remove housing and drill fastener holes.
- (4) Secure jack to mounting surface with No. 8 PH or FH cadmium plated tapping screws.
- (5) Place gland nut, friction washer, and grommet onto cable.
- (6) Run cable inside housing and adjust grommet and friction washer for watertight fit with gland nut.
- (7) Connect conductors to 493A jack.
- (8) Install 493A jack, retainer ring, retainer spring, and cover assembly in this order.
- (9) Tighten locking screw.

KS-19316, List 4 or List 6 Housing

3.05 Install as follows:

- (1) Arrange cable at location selected for jack installation.
- (2) Use housing box with positioned mounting lugs to mark lug mounting holes (Fig. 13).
- (3) Drill holes and secure housing box to mounting surface with No. 8 PH or FH cadmium plated tapping screws.
- (4) Place gland nut, friction washer, and grommet on cable.

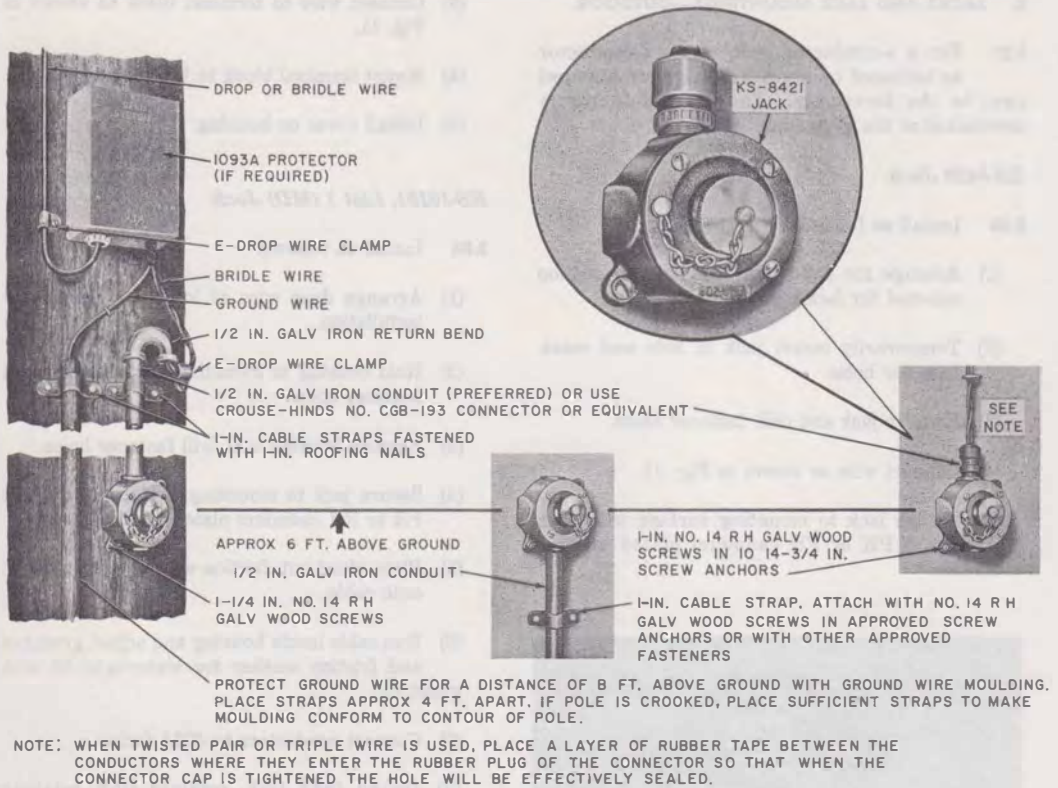

Fig. 12—KS-8421 Jack, Typical Installation

- (5) Run cable inside housing and adjust grommet and friction washer for watertight fit with gland nut.
- (6) Attach bracket to housing box.
- (7) Connect wire or cable to jack.
- (8) Install jack to bracket. Supplied cover for 541A jack is not required and may be discarded.
- (9) Install gasket and cover for watertight fit.

KS-20202, List 1 Housing (Fig. 14)

3.06 Install as follows:

- (1) Arrange cable or drop wire at location selected for installation.
- (2) Hold housing to mounting surface and mark fastener holes.
- (3) Remove housing and drill fastener holes.
- (4) Secure housing to mounting surface with No. 8 PH or FH cadmium plated tapping screws.

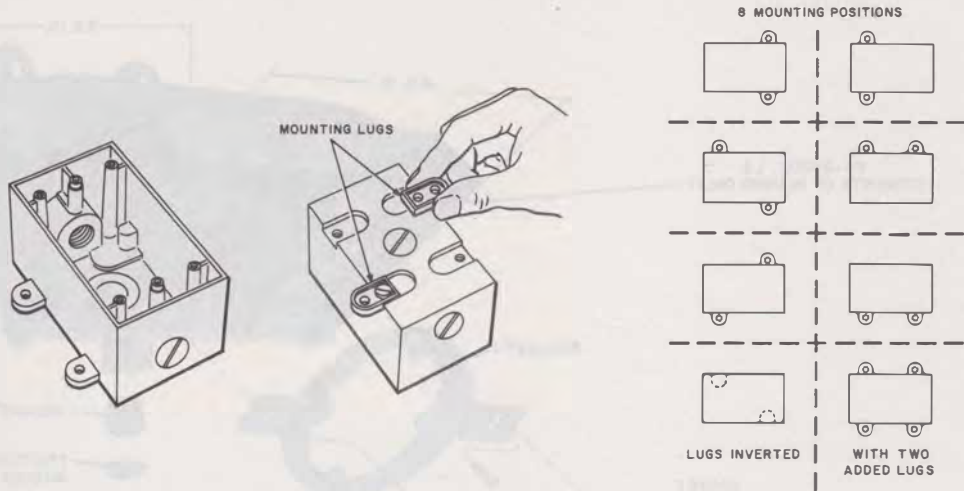

Fig. 13—KS-19316, List 6 Housing Box Showing Reversible Mounting Lugs

- (5) Place gland nut, friction washer and grommet onto cable or drop wire.
- (6) Run cable or drop wire inside housing and adjust grommet and friction washer for watertight fit with gland nut.
- (7) Install bracket and arrange cable or drop wire through center of bracket.
- (8) Connect conductors to selected jack.
- (9) Install jack to bracket. Supplied cover for 541A jack is not required and may be discarded.
- (10) Install gasket and cover.

4. PLUGS-INDOOR AND OUTDOOR (Table C)

504A Plug

4.01 Included with the 504A plug (Fig. 15) is a metal cord stay designed for use with cords equipped with a wire S hook. The S hook is removed and discarded. The cord stay, inserted into the vacated band hole, serves as a wing band.

4.02 Assemble the 504A plug as follows:

- (1) Place cord tip guide on block (Fig. 15).
- (2) Insert mounting cord tips into socket-type terminals of plug.

Note: For mounting cord conductor connections, refer to connection section for the telephone set.

- (3) Dress conductors so they will lie within the cap of plug.
- (4) Place wing band or cord stay of mounting cord in its proper slot.
- (5) Place cap on plug so cord and wing band or cord stay will seat properly. Be sure no leads are pinched.
- (6) Snap two sections of neck together.
- (7) Insert screw and tighten.

505A Plug

4.03 The 505A plug is a 4-contact plug similar to the 504A plug; in addition, however, it

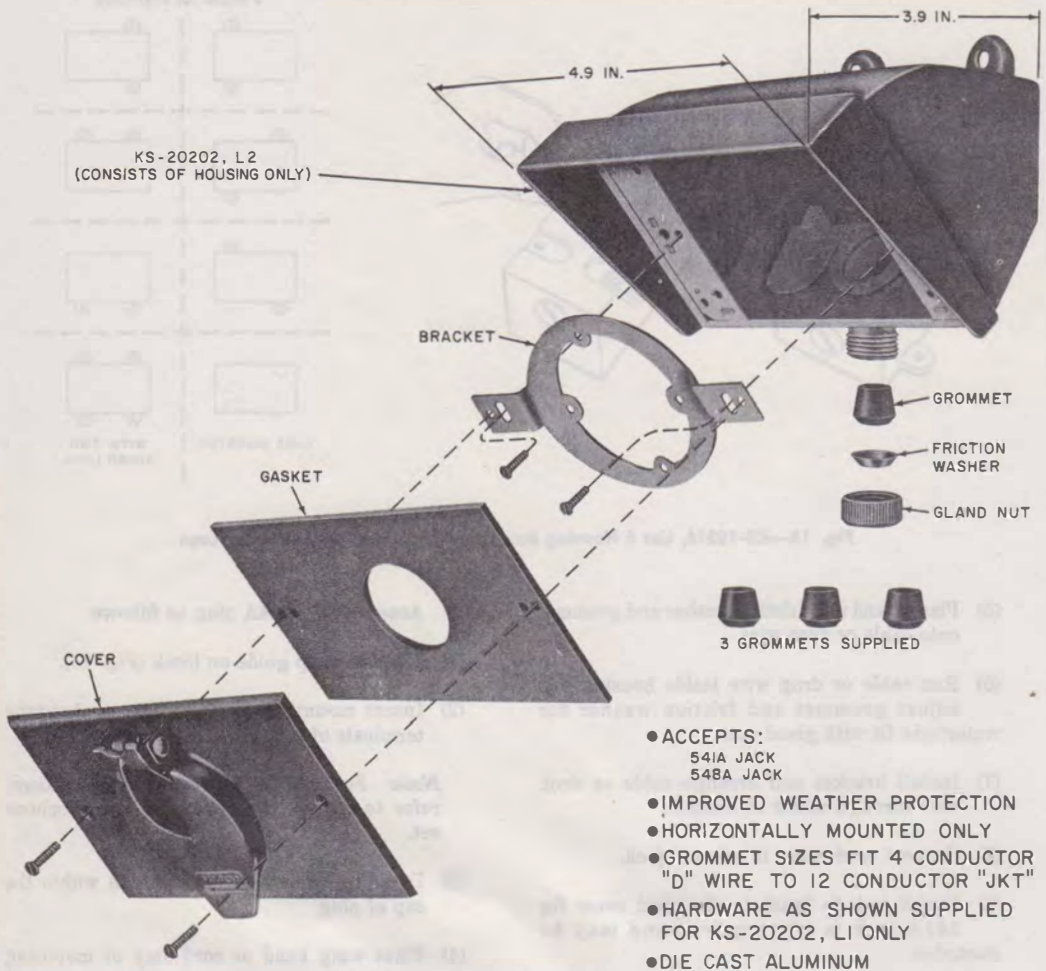

Fig. 14—Assembly of KS-20202, Lists 1 and 2 Weatherproof Housing

TABLE C

PLUGS

TYPE	NO. OF CONTACTS	FIG. NO.	ASSOCIATED JACKS
KS-8419	3	17	KS-8420 KS-8421
505A	4	10,11,12	404B(MD) 493A(MD), 548A, 497A(MD), 549A, 550A, KS-16151, L1(MD)
283B(MD)		14	
423A			
274A	8	13	391A, 392A
504A	12	9	541A, 547A(MD), 551A, 547B

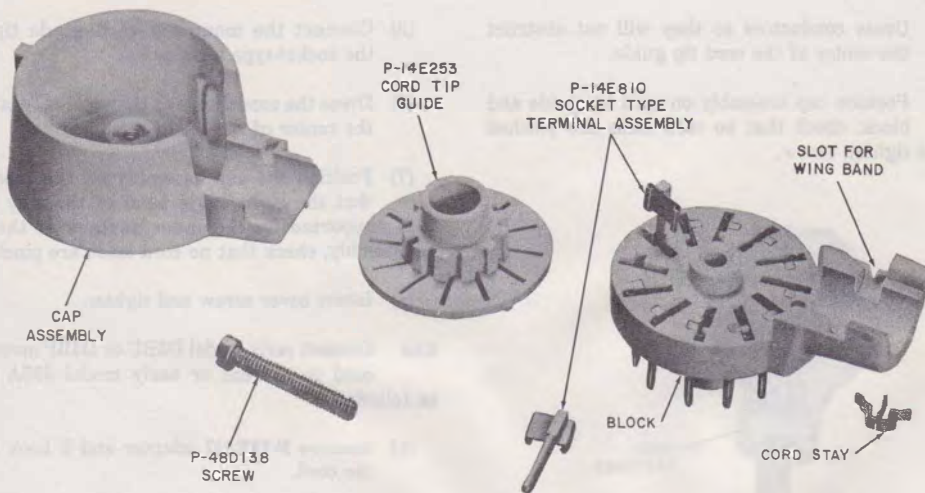

Fig. 15—504A Plug Disassembled

has a cord fastener which holds the cord in place while spade tips are being connected. The cord fastener also anchors the mounting cord in the assembled plug.

4.04 Connect current model D3BU or D4BP mounting cord to a current model 505A plug as follows:

- (1) Position flat eyelet stay band in the cord channel so that the screw hole is over the screw hole in the center of the cord tip guide (see Fig. 16).
- (2) Fit cord fastener into groove in the cord channel and press until it snaps into position.
- (3) Connect the mounting cord space tips in the socket-type terminals.
- (4) Insert screw through hole in block and stay band.
- (5) Dress conductors so they will not obstruct the center of the cord tip guide.
- (6) Position cap assembly on cord tip guide and block; check that no cord leads are pinched and tighten screw.

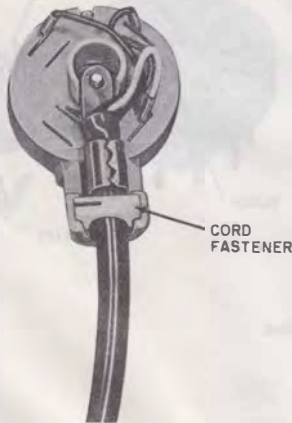

Fig. 16—Current Model D3BU Cord Connected to Current Model 505A Plug

4.05 Connect current model D3BU or D4BP mounting cord to an early model 505A plug as follows:

- (1) Cut flat eyelet stay band approximately 1/8 inch from end of cord jacket using 8-inch sidecutters, or equivalent (Fig. 17).

Caution: *When cutting the stay band, take precautions to prevent the severed end from striking personnel or apparatus.*

- (2) Make a right angle bend in the remaining length of stay band in the direction away from the cord conductors.
- (3) Position the mounting cord into the cord channel of the block, as shown in Fig. 17.
- (4) Fit the cord fastener into the groove in the cord channel and press until it snaps into position.
- (5) Connect the mounting cord spade tips in the socket-type terminals.
- (6) Dress the conductors so they will not obstruct the center of the cord tip guide.
- (7) Position the cap assembly on the block so that the right angle bend of the stay band is supported by the inner surface of the cap assembly; check that no cord leads are pinched.
- (8) Insert cover screw and tighten.

4.06 Connect early model D3BU or D4BP mounting cord to current or early model 505A plug as follows:

- (1) Remove P-18E457 adapter and S hook from the cord.
- (2) Make a right angle bend in the S hook support of the stay band in the direction away from the cord conductors (Fig. 18).
- (3) Position the mounting cord in the cord channel so the S hook support is seated in the slot adjacent to the cord tip guide (Fig. 18).
- (4) Fit the cord fastener into the groove in the cord channel and press until it snaps into position.

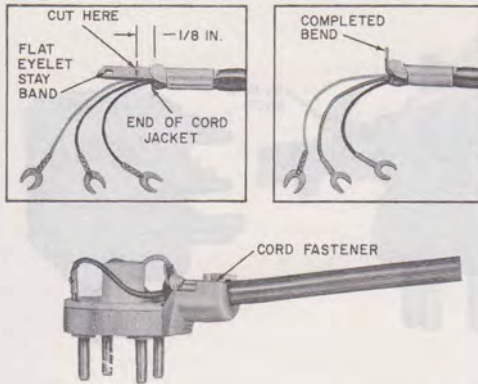

Fig. 17—Connecting Current Model D3BU or D4BP Cord to Early Model 505A Plug

- (5) Connect the mounting cord spade tips in the socket-type terminals.
- (6) Dress cord conductors so they will not obstruct the center of the cord tip guide.
- (7) Position cap assembly on cord tip guide and block; check that leads are not pinched.
- (8) Insert cover screw and tighten.

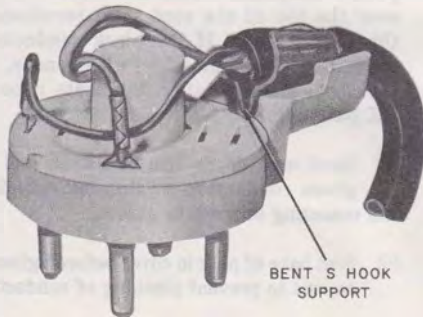

Fig. 18—Early Model D3BU Cord Connected to 505A Plug

4.07 Connect 505A plug to a cord equipped with a wing band as follows:

- (1) Fit the cord tip guide into place on the top of the block.
- (2) Position the mounting cord into the cord channel of the block so that the cord wing band fits into the wing band slot. One ear of the wing band will extend into the wing band slot of the cord fastener.
- (3) Fit the cord fastener into the groove in the cord channel and press until it snaps into position.
- (4) Arrange the mounting cord spade tips in the socket-type terminals.
- (5) Adjust the conductors so that they will not obstruct the center of the cord tip guide.

274A Plug

4.08 The 274A plug (Fig. 19) is a 2-piece, 8-contact plug of molded plastic intended for use with braided fabric covered mounting cords.

4.09 Connect 274A plug as follows:

- (1) Connect as indicated by color designations stamped adjacent to terminals.
- (2) Connect cord spade tips as shown in Fig. 19.
- (3) Tie mounting cord securely.
- (4) Place shell on base and tighten screws.

423A Plug

4.10 Connect the 423A plug as follows:

- (1) Connect as indicated by color designations stamped adjacent to terminals.
- (2) Lay jacketed portion of cord in the two molded U-shaped projections.
- (3) Place cover on base and tighten screw.

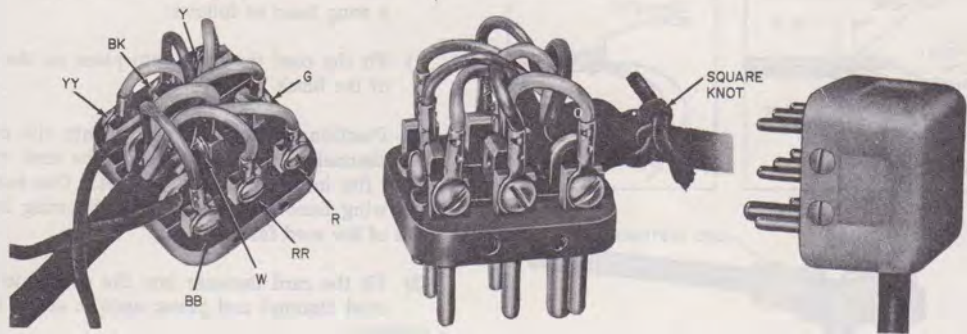

Fig. 19—274A Plug

283B (MD) Plug

4.11 Connect 283B (MD) plugs as follows:

(a) Using Current Model D3BU or D4BP Cord:

- (1) Make a slight bend in the flat eyelet stay band in the direction away from the cord conductors.
- (2) With cord conductors up, insert RM-658901 self-tapping screw with P-284139 flat washer (shipped with 283B [MD] plug) through hole in stay band. Using farthest hole opposite cord entrance, anchor cord securely (Fig. 20).
- (3) Connect as indicated by color designations stamped adjacent to terminals.
- (4) Seat base of plug in its cover; check that no cord leads are pinched. Tighten cover screws.

(b) Using Early Model D3BU or D4BP Cord:

- (1) Remove P-18E457 adapter from cord (Fig. 21).
- (2) Using long-nose pliers and 8-inch sidecutters or equivalent (Fig. 22), turn large eye of S hook clockwise until positioned 90 degrees away from small eye of S hook.
- (3) With small eye of S hook up, insert RM-658901 self-tapping screw with P-284139

flat washer through large eye of S hook. Using farthest hole opposite cord entrance anchor cord securely.

Note: An RM-658901 self-tapping screw and a P-284139 flat washer will be shipped with each 283B (MD) plug.

- (4) Lay the cord conductors out straight from the cord. Pass the green conductor clockwise under the cord stay and terminate it on the GN punching. Pass the red conductor counterclockwise under the cord stay and terminate it on the R punching. Pass the yellow conductor clockwise under and then over the top of the cord stay; terminate on the Y punching. If the black conductor is used, pass it counterclockwise, under, and then over the cord stay; terminate it on the BK punching.
- (5) Bend cord spade tips and dress red and green conductors so they lie outside of the mounting screw hole guides.
- (6) Seat base of plug in cover before tightening screws to prevent pinching of conductors.

(c) Using Cord Equipped With Wing Band:

- (1) Connect as indicated by color designations stamped adjacent to terminals (Fig. 20).
- (2) Bend cord spade tips up as shown in Fig. 20.

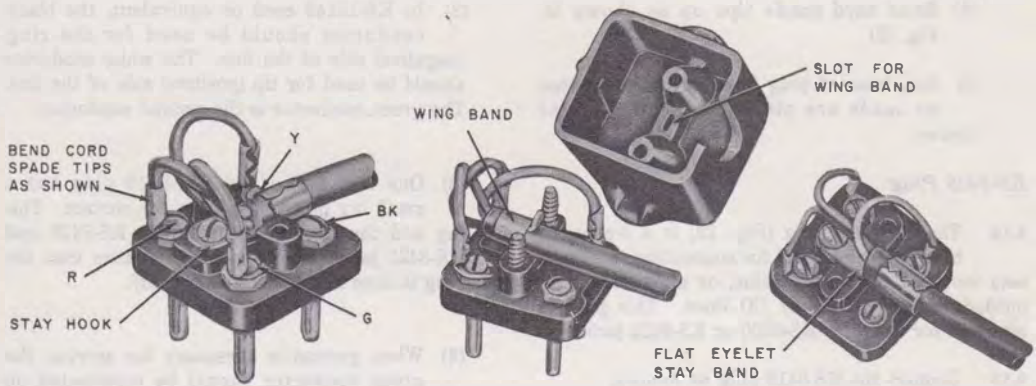

Fig. 20—Terminating Cords Equipped with a Stay Hook, Wing Bond, or Flat Eyelet Stay Band on a 283B (MD) Plug

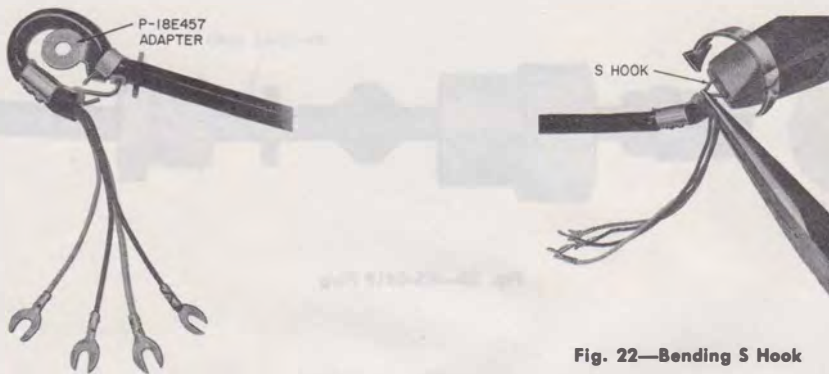

Fig. 21—Early Model D4BP Cord and Adapter

Fig. 22—Bending S Hook

(3) Place one edge of wing band in the larger (shallow drilled) of the two holes in the base.

(4) Place cover so cord and wing band will seat properly in their slots.

(5) Seat base of plug in its cover before tightening screws to prevent pinching of cord conductors.

(d) *Using Cord Equipped With Stay Hook:*

(1) Insert RM-658901 self-tapping screw through P-284139 flat washer. Using farthest hole opposite cord entrance, start screw into hole.

(2) With cord conductors up, slide cutout in stay hook under flat washer and tighten screw.

(3) Connect as indicated by color designations stamped adjacent to terminals (Fig. 20).

- (4) Bend cord spade tips up as shown in Fig. 20.
- (5) Seat base of plug in its cover; check that no leads are pinched. Tighten cover screws.

KS-8419 Plug

4.12 The KS-8419 plug (Fig. 23) is a 3-contact, brass plug intended for connecting telephone sets installed on boats, trains, or auto trailers to outdoor jacks of PBX or CO lines. This plug is intended for use with KS-8420 or KS-8421 jacks.

4.13 Connect the KS-8419 plug as follows:

- (1) Plug components are assembled to KS-15143 3-conductor, 18-gauge cord or equivalent (Fig. 23).

- (2) In KS-15143 cord or equivalent, the black conductor should be used for the ring (negative) side of the line. The white conductor should be used for tip (positive) side of the line. The green conductor is the ground conductor.

- (3) One terminal of the KS-8419 plug has a small lug protruding from the contact. This lug and the notched terminal on KS-8420 and KS-8421 jacks are provided to ensure that the plug is inserted in one position only.

- (4) When ground is necessary for service, the green conductor should be terminated on the notched terminal.

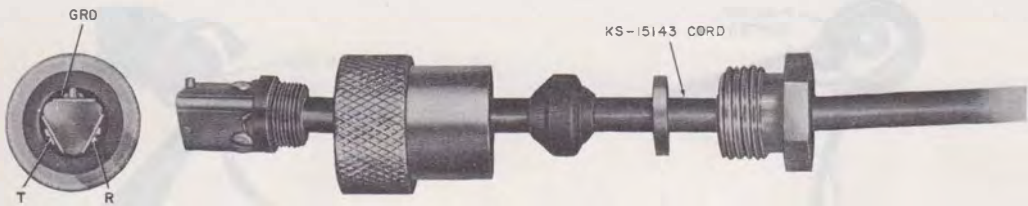

Fig. 23—KS-8419 Plug