

SPECIAL SAFEGUARD MEASURES (SSM) AND SPECIAL SERVICE PROTECTION (SSP)

1. GENERAL

1.01 This section provides information on protective devices used on special service circuits requiring special safeguard measures (SSM) or special service protection (SSP); these devices are used to guard against *accidental mechanical contact* and resulting disturbance of the circuits.

1.02 Special service circuits as discussed in this section are cable and wire facilities furnished by the telephone company to connect with customer owned and maintained (COAM) and telephone company maintained (TCM) equipment, other than that used to provide exchange telephone service.

1.03 This section is reissued to:

- Add KS-20353, List 1 guard
- Add KS-21369 guard
- Add KS-14539, List 10 and List 11 guard
- Add terminal punching insulators No. 8 and No. 9
- Add E clip terminal insulator
- Add F clip terminal insulator
- Include information on SSP for 303 connector terminals
- Include information on SSP for 300 connector terminals having a double-wrapped special service circuit
- Add KS-21168, List 1 terminal insulator
- Add 20A circuit guard
- Rate 12-type guards MD
- Rate KS-14539, List 6 guard MD

- Rate KS-16576, List 5 and List 6 designation plates MD
- Include information formerly contained in Section 460-110-400.

Since this reissue covers a general revision, arrows ordinarily used to indicate changes have been omitted.

2. ORDERING GUIDE

- Indicator, KS-6660, Fig. 3
- Indicator, KS-16847, Fig. 3
- Cap, Post, Binding, B, Fig. 4
- Cap, Post, Binding, C, Fig. 4
- Cap, Post, Binding, D, Fig. 4
- Cap, Post, Binding, E, Fig. 4
- Cap, Post, Binding, F, Fig. 4
- Cap, Post, Binding, G, Fig. 4
- Cap, Post, Binding, H, Fig. 4
- Guard, KS-14539, List 5, Fig. 5
- Guard, KS-14539, List 10 and List 11, Fig. 6
- Insulator, Post, Binding, No. 1, Fig. 7
- Insulator, Post, Binding, No. 2, Fig. 7
- Insulator, Post, Binding, No. 3, Fig. 7
- Insulator, Post, Binding, No. 6, Fig. 7
- Insulator, Punching, Terminal, No. 4, Fig. 8
- Insulator, Punching, Terminal, No. 5, Fig. 8

- Insulator, Punching, Terminal, No. 7, Fig. 8
- Insulator, Punching, Terminal, No. 8, Fig. 8
- Insulator, Punching, Terminal, No. 9, Fig. 8
- Insulator, Terminal, Clip B, Fig. 10
- Insulator, Terminal, Clip C, Fig. 10
- Insulator, Terminal, Clip D, Fig. 10
- Insulator, Terminal, Clip E, Fig. 10
- Insulator, Terminal, Clip F, Fig. 10
- Insulator, Terminal, KS-21168, List 1, Fig. 11
- Guard, KS-20353, List 1, Fig. 13
- Form E-5190, Warning Marker, Fig. 14
- Cap, P-16E564 Heat Coil, Fig. 16
- Guard, KS-21369, List 1, Fig. 17
- Tie, Cable, KS-20986, List 4 or List 3 (used with KS-21369, L1 guard when SSM is required), Fig. 17
- Guard, Circuit, 20A, Fig. 18

3. SPECIAL SERVICE PROTECTION (SSP)

3.01 Special service circuits designated "SSP" require special protection to insure that plant functions do not interfere with their operations. These circuits are of such a nature that momentary shorts, opens, or accidental contact may cause serious reaction in customer relations.

3.02 Binding post insulators and caps, pair indicators, and PBX frame guards are provided for field forces to place in terminals, PBX frames and bridging locations where special service circuits appear. In addition to physical protection, these markings and protective devices are an indication that *approval from the Serving Service Center is necessary before doing any work on these circuits.*

4. SPECIAL SAFEGUARDING MEASURES (SSM)

4.01 The same protection used for SSP is required for SSM; in addition, locked terminals, unbridged pairs, wire in conduit, and cable in lieu of drop wire are required. Engineering authorization is required to establish SSM.

4.02 Special safeguarding measures (SSM) are primarily used on services involving National Security.

5. WORK ORDERS

5.01 The special service order and/or the toll circuit layout order is noted "SSP" or "SSM" alongside the circuit number. In addition, Form E-4106 (Fig. 1) is used to notify the field forces where to place or remove protection when SSP or SSM is involved.

BINDING POST INSULATORS TERMINALS		PROTECTOR GUARD DEVICES DISTRIBUTING FRAMES		
CENTRAL OFFICE	SHERWOOD	DUE DATE	8-15-60	
DATE ISSUED	8/11	BY	LR	
WORK ORD. NO.		SERVICE ORD. NO.	4073	
TRANS. NO.		FOR INFORMATION CALL	742-8163	
COPY FOR FIELD				
PLACE AND UP REMOVE SPECIAL SERVICE PROTECTION AT LOCATIONS LISTED				
CABLE	PAIR	BP	TERMINAL LOCATION	PROTECTION PLACE REMOVE
21	22	8	F 310 STYLES	X
()		F 437 HARMON AV.	X
{	}	13	R 42 CAROL RD.	X
		9	R 48 " "	X
		5	R 54 " "	X
		14	R 76 " "	X
WORK COMPLETED BY _____ DATE _____ O.K. NO. _____				

Fig. 1—Facsimile of Form E-4106

5.02 Typical circuits requiring SSP and/or SSM are:

- (a) Program transmission and television circuits
- (b) Telephotograph, telautograph, and facsimile transmission facilities

- (c) Private line signal channel or radiotelephone circuits
- (d) Telegraph and Teletypewriter leased line
- (e) TWX lines
- (f) Clock or ADT lines that operate on closed or series circuits
- (g) Remote control, signaling, metering, data circuits, and alarm circuits for fire, police, burglar, and watchman
- (h) Special facilities for defense or major disaster
- (i) Civil air defense warning network
- (j) Power company remote control circuits
- (k) Airway communication circuits
- (l) PBX battery and generator supply for hospitals, police and fire departments, or agencies who perform emergency service for the general public.

6. HOW TO AVOID DIFFICULTIES!

- **Obtain authorization before working on a special circuit.**
- Use SSP and/or SSM when required.
- Use 1013A or equivalent hand test set with capacitor in line (monitor position) when first going across a pair.
- Do not short terminals when trying to locate a pair (Fig. 2).
- Exercise care to avoid accidental contact with other lines.
- Obtain authorization before removing any SSP and/or SSM.

7. PROTECTIVE DEVICES

- 7.01** Common protective devices used on special service circuits are shown in Fig. 3 through 18.

Indicators (Fig. 3)

7.02 Indicator KS-6660 is a red plastic ring 1/2 inch in diameter. This indicator must be placed on wires before they are terminated. Indicator KS-16847 is a red cellulose-acetate spiral ring, 3/8 inch in diameter. The split-ring feature of this indicator permits placing or removing indicator on terminated wires.

Binding Post Caps (Fig. 4)

7.03 Binding post caps are neoprene caps for use on cable and wire terminals as protection against accidental contacts on special service lines and as a means of minimizing faceplate leakage in distribution cable terminals. They are available in red and black colors. Red caps are intended for use on special service lines and the black caps are for general use.

7.04 Applications for these binding post caps are as follows.

- The B binding post caps are for use on **nonworking** posts of N, T, and 61-type cable terminals.
- The C binding post caps are for use on **working** posts of N, T, and 61-type cable terminals.
- The D binding post caps are for use on 7A fuses installed in L-type fuse chambers.
- The E binding post caps are for use on 49-type cable terminals.
- The F binding post caps are for use on terminals equipped with insulation crushing washers such as B buried cable terminals, 30-2, 57B, and 59A-type (MD) connecting blocks.
- The G binding post caps are for use on 30-type connecting blocks.
- The H binding post caps are for use on 31-type connecting blocks.

KS-14539, List 5 Guard (Fig. 5)

7.05 The KS-14539, List 5 guard is a red plastic hood designed to cover the heat coils and

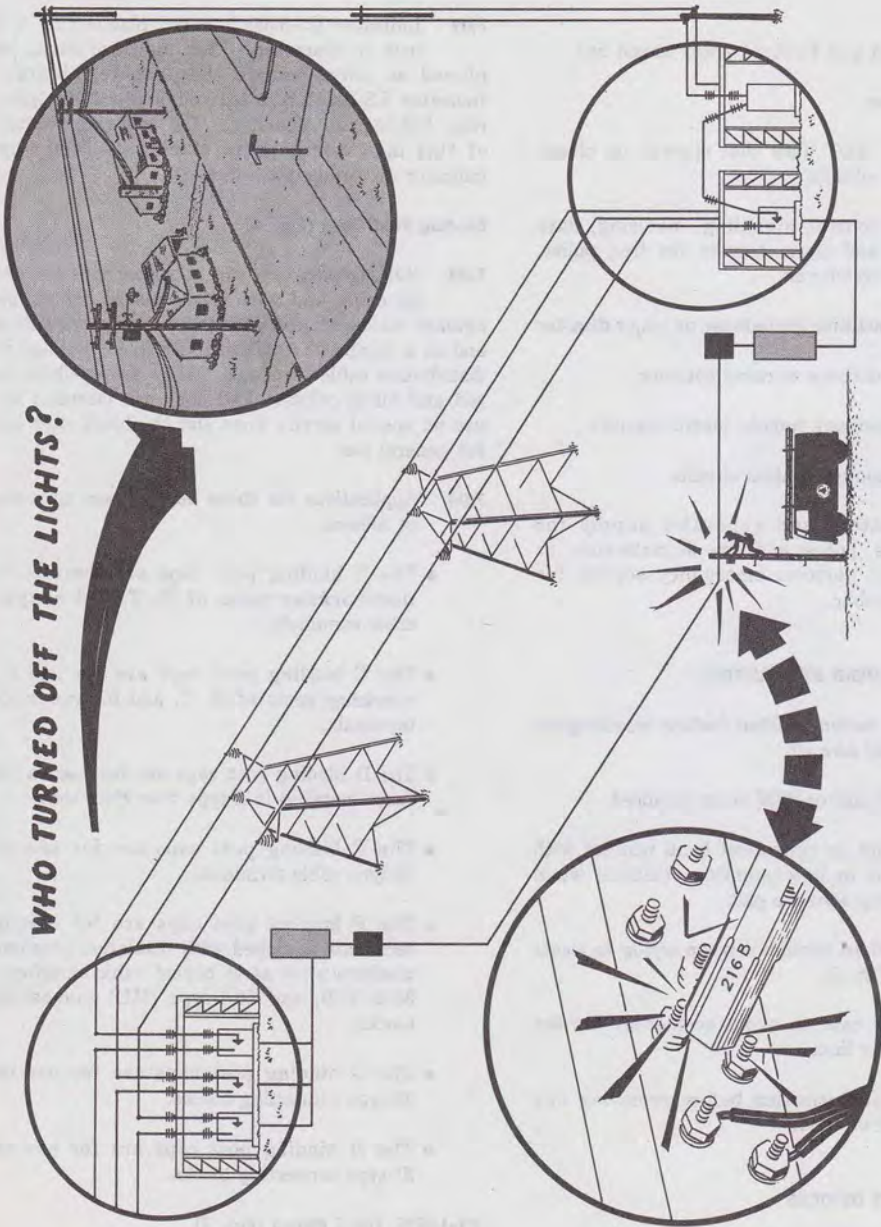

Fig. 2—Who Turned Off The Lights?

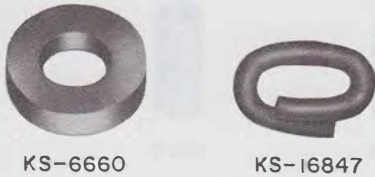

Fig. 3—KS-6660 and KS-16847 Indicators

springs on 1177-type protectors. **Remember—protect each special circuit appearing on frame. Place SSP on each end of jumper wire.**

KS-14539, List 10 and List 11 Guard (Fig. 6)

7.06 The KS-14539, List 10 and List 11 guard is a red, flame retardant plastic wrap around guard with a beaded cable tie, designed to insulate, protect, and designate SSP and SSM circuit pairs on C50 and C52 protectors. The KS-14539, List 10 is the guard **only** which is used when **SSP** is



Fig. 4—Binding Post Caps



Fig. 5—KS-14539, List 5 Guard

required; the KS-14539, List 11 is the guard **and** cable tie which is used when **SSM** is required.

7.07 The KS-14539, List 10 guard is used in place of two KS-14539, List 6 guards (MD) and four terminal punching insulators to designate and insulate a circuit pair on the C50-type protector. The physical design of the List 10 allows a dislodged heat coil to fall to the floor level, preventing an accumulation of dislodged heat coils and possible short circuit.

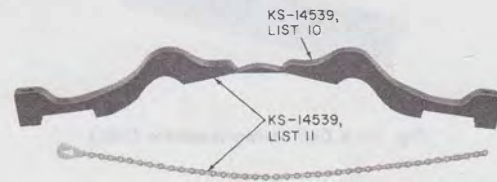

Fig. 6—KS-14539, List 10 and List 11 Guard

7.08 The KS-14539, List 10 and List 11 guard is installed as shown in Fig. 32. When **SSM** is required, the List 11 is installed by threading the beaded cable tie through the keyhole slot on one end of the guard, around the fanning strip, and through the keyhole slot on the opposite end. The tie is then drawn tight, locked in place and cut, leaving the end of the cable tie approximately one inch long.

Binding Post Insulators (Fig. 7)

7.09 Binding post insulators are open-ended, red, flame retardant plastic insulators for use on binding posts to prevent accidental contact. These insulators are designated No. 1, 2, 3, and 6.



Fig. 7—Binding Post Insulators

7.10 Applications for these binding post insulators are as follows.

- No. 1 insulators are for use on binding posts having 3/8-inch hexagonal nuts, and on 7T fuses.
- No. 2 insulators are for use on binding posts having 7/16-inch hexagonal nuts, and on 7A fuses.
- No. 3 insulators fit the screw binding posts of BD, BE, BF, BG, BH, and BJ cable terminals.
- No. 6 insulators are for use on terminations of the alarm and contactor circuits in T pressure contactor terminals and 3-pair gas-tight terminals.

Terminal Punching Insulators (Fig. 8)

7.11 Terminal punching insulators are open-ended, red, flame retardant plastic insulators for use on 300 connector terminals and terminal punchings to prevent accidental contacts. These insulators are designated No. 4, 5, 7, 8, and 9.

7.12 Applications for these terminal punching insulators are as follows.

- No. 4 and No. 5 insulators are 1/2 inch and 5/8 inch, respectively, in length and are used on 300 connector terminals and terminal strips.

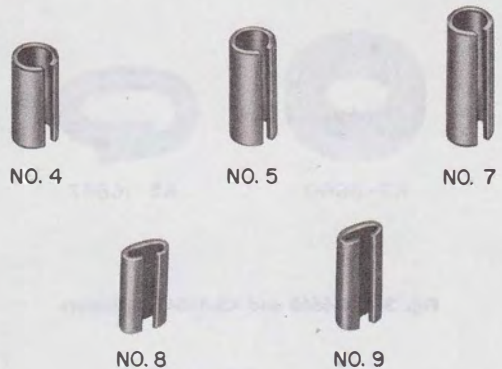

Fig. 8—Terminal Punching Insulators

- No. 7 insulators are 3/4 inch in length, and are used on cable conductor terminating lugs of the C- and E-type protector mountings.
- No. 8 and No. 9 insulators are 1/2 inch and 5/8 inch, respectively, in length and are used on terminal strips where terminal spacing and wire build-up create a space problem.

B Coil Spring Insulator, MD (Fig. 9)

7.13 The B coil spring insulator is a fiber insulator designed for use on 70-type (MD) connecting block. When installed, one B insulator will protect two coil springs, tip and ring, that are mounted on the face or station side of block. It has a red enamel finish.



Fig. 9—B Coil Spring Insulator (MD)

Clip Terminal Insulators (Fig. 10)

7.14 Clip terminal insulators are red plastic insulators designed to protect terminals on

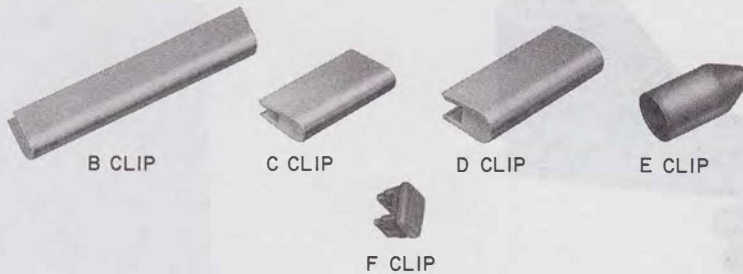

Fig. 10—Clip Terminal Insulators

66-type, 78-type, 5A1-type, and 88-type connecting blocks.

7.15 Applications for the clip terminal insulators are as follows.

- The B clip terminal insulator is approximately two inches long and is designed to protect one row of terminals on 66-type connecting blocks or may be cut to fit the desired number of terminals.
- The C clip terminal insulator is approximately 1/2 inch long with closed ends and is designed to protect two terminals on 66G-type and 78A-type connecting blocks.
- The D clip terminal insulator is approximately 7/8 inch long with closed ends and is designed to protect two terminals on 66H-type and 78B-type connecting blocks.
- The E clip terminal insulator is designed to protect a single terminal on 5A1 or 66-type connecting blocks.
- The F clip terminal insulator is designed to protect two terminals on an 88-type connecting block.

KS-21168, List 1 Terminal Insulator (Fig. 11)

7.16 The KS-21168, List 1 terminal insulator is a dual, open-ended, red, flame retardant plastic insulator used to insulate, protect, and designate special service *pairs* on 303-type connector terminals. The insulator may be expanded or compressed to fit snugly over the wire wrap terminal lugs;



Fig. 11—KS-21168, List 1 Terminal Insulator

longitudinal slots provide clearance for bridged pairs. These insulators are recommended for use on 303-type connector terminals instead of No. 5 terminal punching insulators because of ease of handling, positive engagement, and one KS-21168, L1 insulator serves the function of two No. 5 insulators.

12-Type Guard, MD (Fig. 12)

7.17 The 12-type guards are designed to protect special service lines appearing on frames that are equipped with 444A test jacks. The 12B guard (Fig. 12) is the same as the 12A guard, except that it is equipped with a locking screw for maximum security. The 12-type guards have metal frames and brown phenolic fiber sides. They are replaced by the KS-20353, List 1 guard.

KS-20353, List 1 Guard (Fig. 13)

7.18 The KS-20353, List 1 guard is a red plastic guard for use in protecting pair positions of the 444 jack on distributing frames against accidental contact. It consists of a cavity on one side and a rectangular hole through the other.

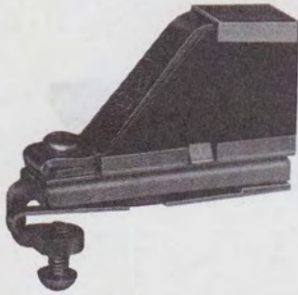

Fig. 12—12B Guard (MD)

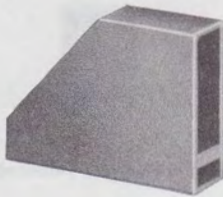

Fig. 13—KS-20353, List 1 Guard

Warning Marker, Form E-5190 (Fig. 14)

7.19 The warning marker Form E-5190 is a red, waterproof plastic cloth with a pressure sensitive backing. The tapes are 1/4 inch wide by 1-1/2 inches long and are supplied on a dispenser card with 36 tapes to a card. It is designed for identification of special lines joined by B wire connectors.

KS-16576 Designation Plates, MD (Fig. 15)

7.20 The KS-16576, List 5 designation plate is a red plastic hood designed to cover the wire-wrap terminals of one pair on the jumper wire side of 300-type connectors.

7.21 The KS-16576, List 6 designation plate is a red plastic hood designed to cover the test terminals of one pair on the cable side of 300-type connectors.

7.22 The KS-16576, List 5 and List 6 designation plates are replaced by the KS-21369, List 1 guard.

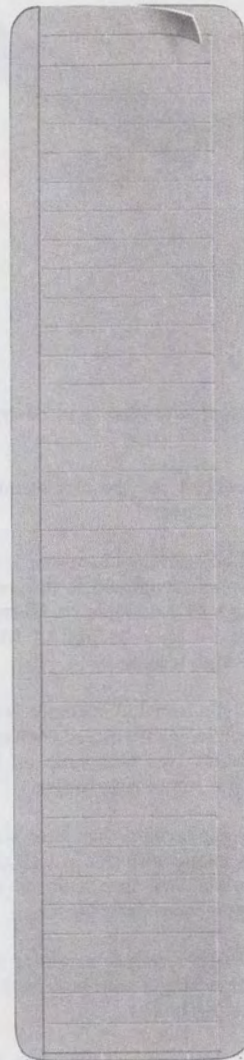

Fig. 14—Warning Marker Form E-5190

P-16E564 Heat Coil Cap (Fig. 16)

7.23 The P-16E564 heat coil cap is a red plastic cap used in conjunction with the KS-21369, List 1 guard to provide SSM and SSP on 300-type connectors. These caps are used with the protector



LIST 5

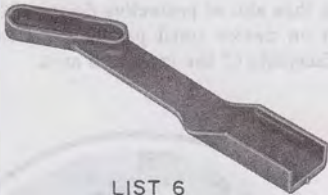

LIST 6

Fig. 15—KS-16576 Designation Plates (MD)



Fig. 16—P-16E564 Heat Coil Cap

units to indicate a special line and to prevent accidental opening of the line.

KS-21369, List 1 Guard and KS-20986 Cable Tie (Fig. 17)

7.24 The KS-21369, List 1 guard is a red, flame retardant plastic wrap around guard designed to insulate, protect, and designate SSP and SSM circuit pairs on the 300-type connectors. The KS-21369, List 1 guard is used when **SSP** is required; when **SSM** is required, a KS-20986 cable

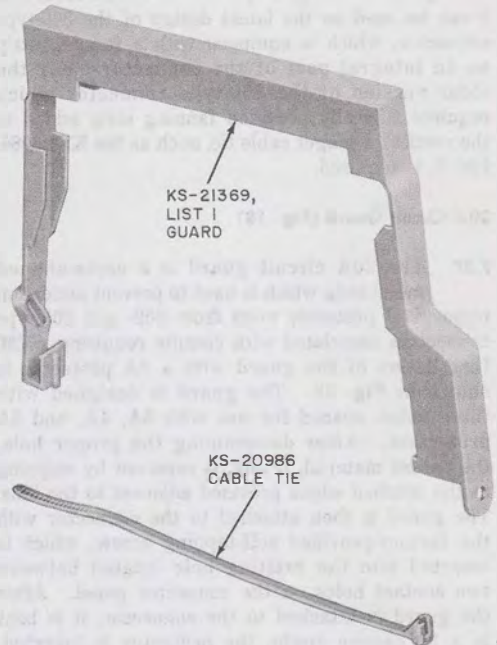

Fig. 17—KS-21369, List 1 Guard and KS-20986 Cable Tie

tie is used to secure the guard to the fanning strip on the 300-type connector. The KS-21369, List 1 guard replaces the KS-16576, List 5 and List 6 designation plates which are rated MD.

7.25 The KS-21369, List 1 guard is installed as shown in Fig. 36. The hook on the end of the left arm is attached to the rear of the left edge of the 300-type connector, covering the test points of the special circuit with the cap on the left arm. The guard is then wrapped around the front of the panel, over both protector units, and the right arm is snapped into place on the ribs of the right edge of the connector, thereby enclosing the wire-wrap terminals.

7.26 When **SSM** is required, the KS-21369, List 1 guard can be secured to the fanning strip of the 300-type connector by threading a KS-20986 self-locking, nonreleasing cable tie through the hole in the end of the right arm of the guard and

through the fanning strip slot. The KS-20986, List 4 can be used on the latest design of the 300-type connector, which is equipped with a fanning strip as an integral part of the connector. For the older version of the 300-type connector which requires a locally provided fanning strip added to the vertical, a longer cable tie, such as the KS-20986, List 3, is required.

20A Circuit Guard (Fig. 18)

7.27 The 20A circuit guard is a cross-shaped metal strip which is used to prevent accidental removal of protector units from 302- and 303-type connectors associated with circuits requiring *SSM*. Installation of the guard with a 4A protector is shown in Fig. 38. The guard is designed with three holes, spaced for use with 3A, 4A, and 5A protectors. After determining the proper hole, the excess material, if any, is removed by snipping at the notched edges provided adjacent to the hole. The guard is then attached to the connector with the factory-provided self-tapping screw, which is inserted into the existing hole located between two contact holes on the connector panel. After the guard is attached to the connector, it is bent to a 90 degree angle, the protector is inserted, covering the screw head, and the three tabs on the locking end of the guard are bent around the edges of the "T" shaped pull handle of the protector, locking it in the inserted position.

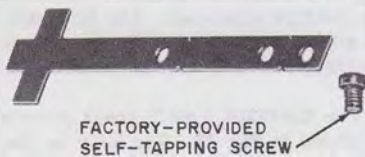

Fig. 18—20A Circuit Guard

8. INSTALLING AND REMOVING SSP (Fig. 19-39)

8.01 Special service protection may be installed or removed upon receipt of Form E-4106 (Fig. 1). It is essential that special service lines be protected at all times. **Remember**—SSP is required at both ends of cross-connecting wires. Install SSP on binding post caps, terminals, etc, as follows.

- (1) Select wire pairs to be protected.
- (2) Make sure terminals and surface areas are clean and free from foreign materials before installing protective device.
- (3) Prior to terminating special service lines, slip the KS-6660 indicator over wire ends to be identified. The split-ring feature of the KS-16847 indicator permits placing or removing indicator on terminated wires.
- (4) Place caps, terminal insulators, guards, etc, over terminal(s) to be protected by dressing wires thru slot of protective devices (if provided). Push on device until properly seated against the faceplate of the protected area.



Fig. 19—Installing Binding Post Caps



Fig. 20—Installed Binding Post Caps with KS-6660 Indicator

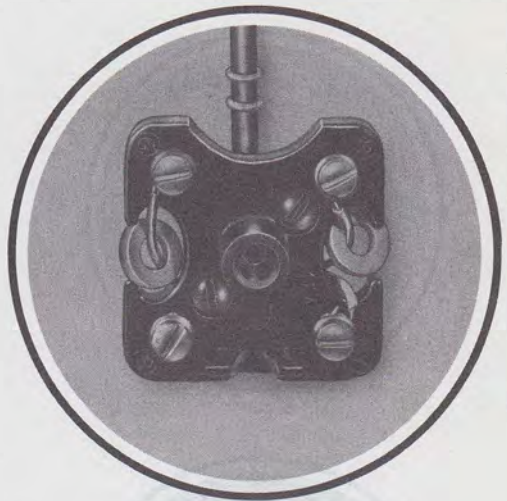

42A

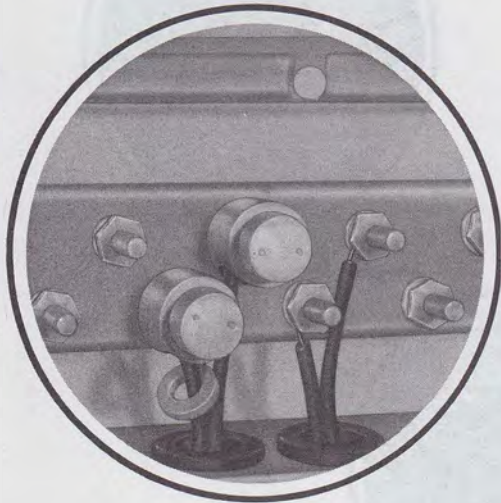

Fig. 21—Installed Binding Post Caps and Indicator At N-Type Cable Terminals

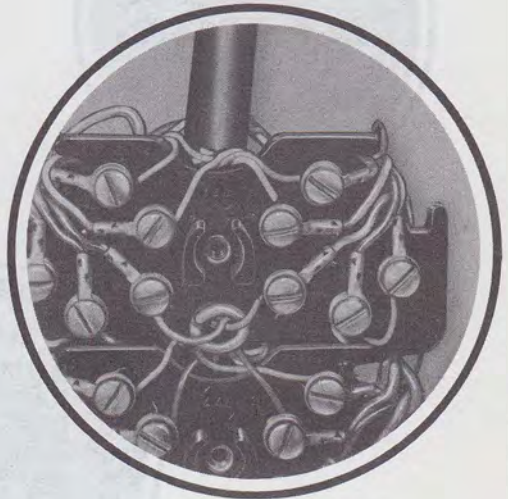
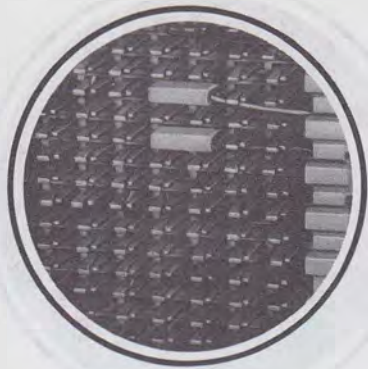

Fig. 22—Typical SSP Used With 42A or 44A Connecting Blocks



B CLIP



C CLIP



D CLIP

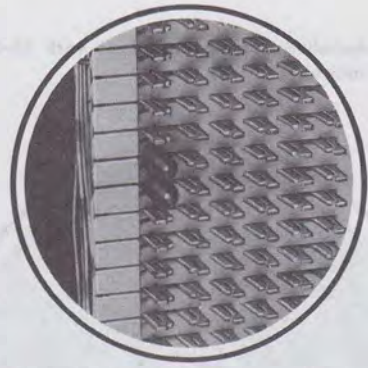

E CLIP

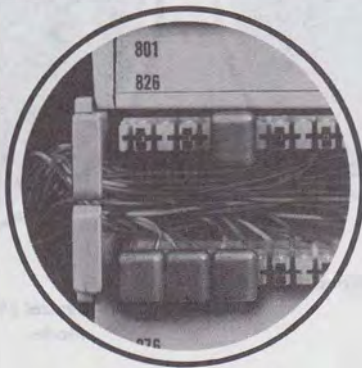

F CLIP

Fig. 23—Clip Terminal Insulators Installed on Connecting Blocks

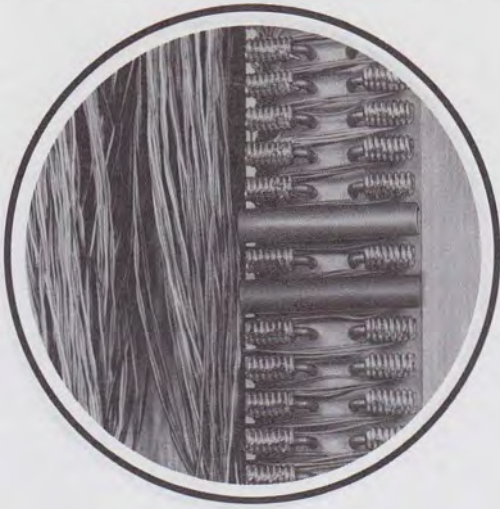

Fig. 24—B Coil Spring Insulators (MD) Installed on 70-Type Connecting Block (MD)

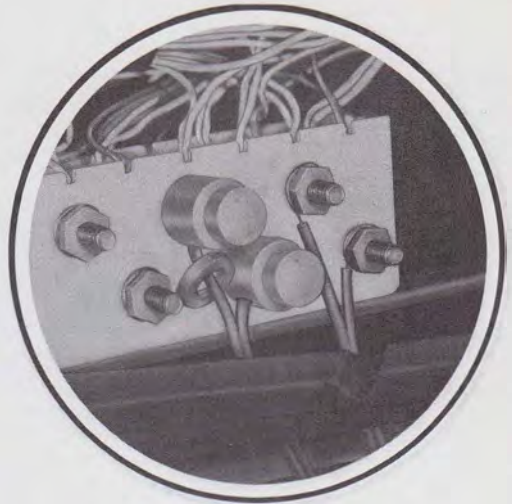

Fig. 26—E Binding Post Caps and Indicators Installed on 49A Cable Terminals

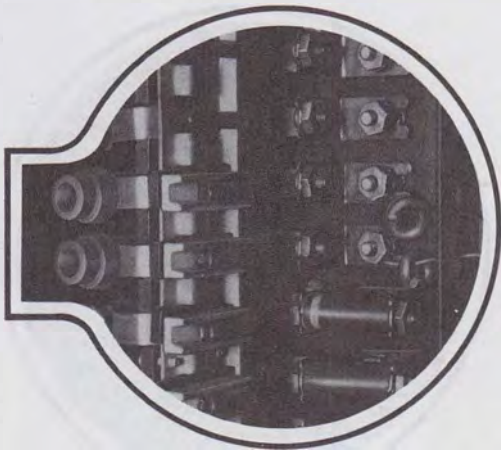

Fig. 25—D Binding Post Caps and Indicators Installed in L-Type Fuse Chamber

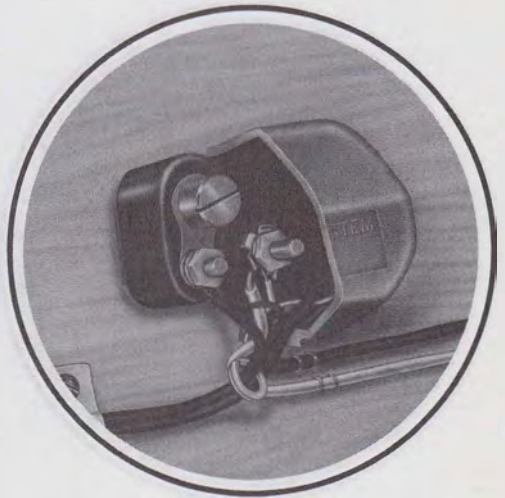

Fig. 27—KS-16847 Indicator Used With Station Protector

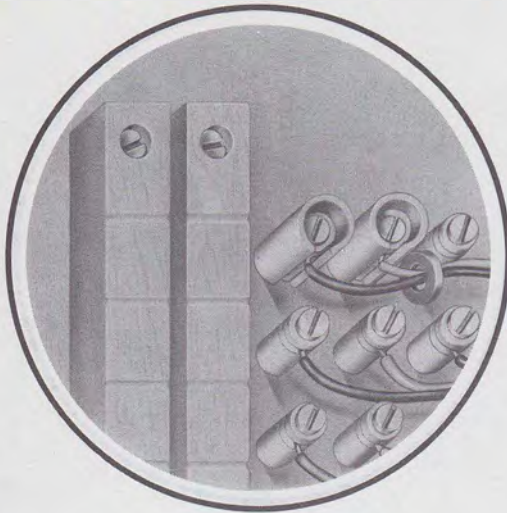

Fig. 28—Binding Post Insulators Installed at BD-Type Cable Terminals

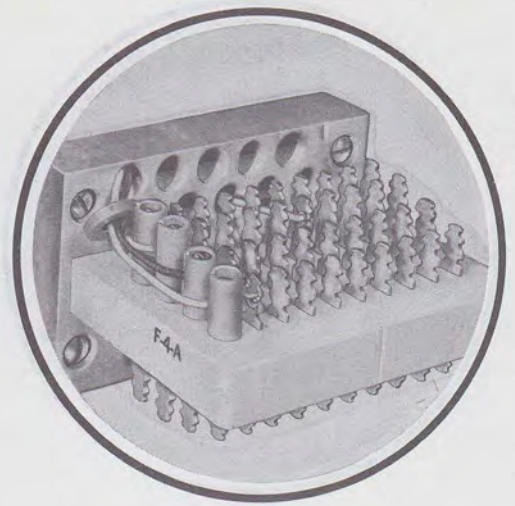

Fig. 30—Typical Installation Using Two Sizes of Punching Insulators on Same Connecting Block

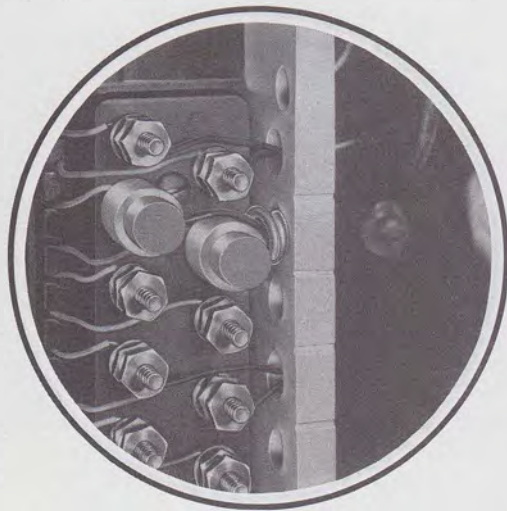

Fig. 29—Typical SSP at 30-Type Connecting Block

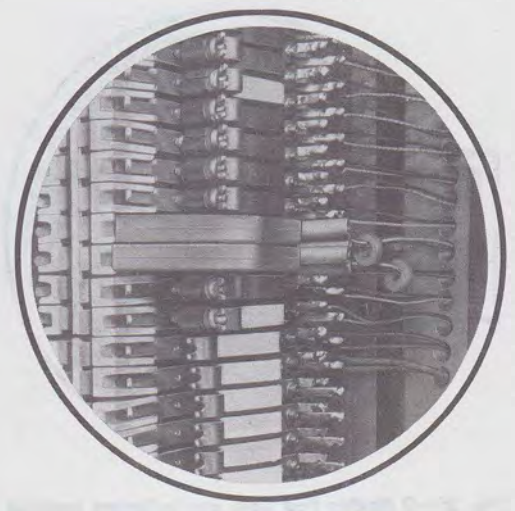

Fig. 31—KS-14539, List 5 Guard Installed on 1177 Protector

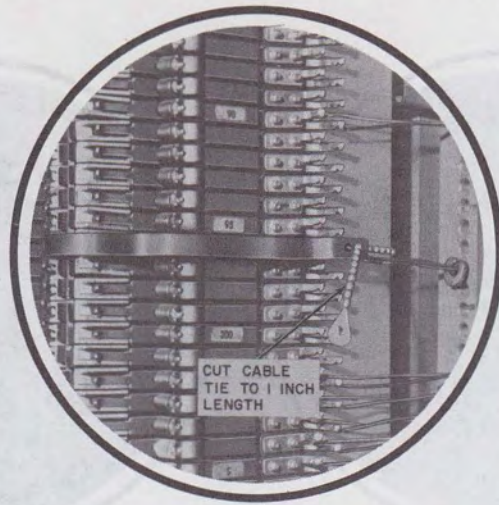

Fig. 32—KS-14539, List 11 Guard Installed on C50-Type Protector

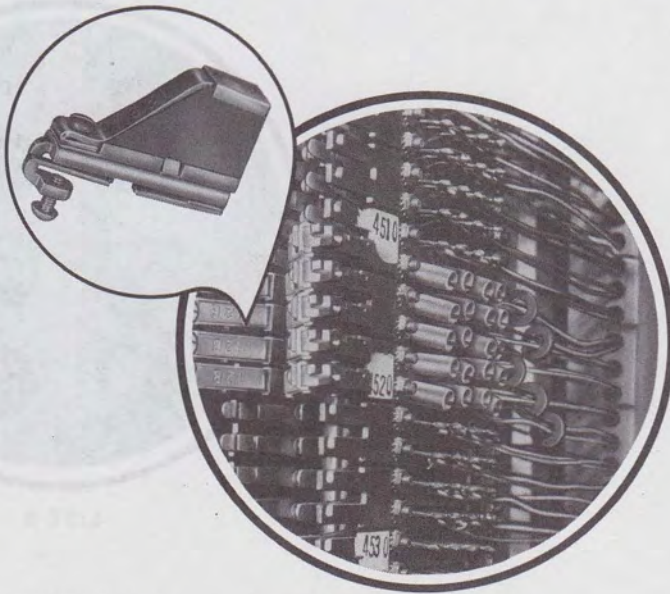

Fig. 33—SSP on Frame Equipped With 444A Test Jacks on 401 Connector

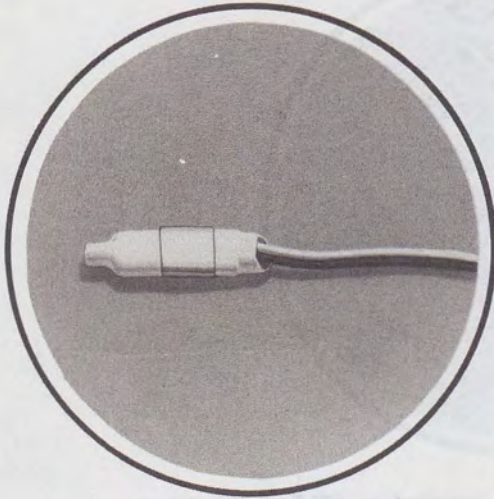
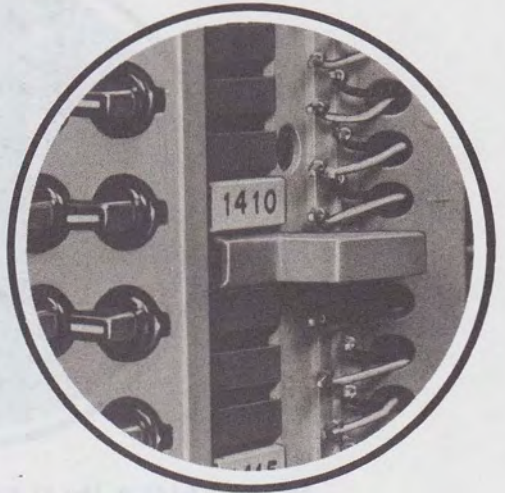
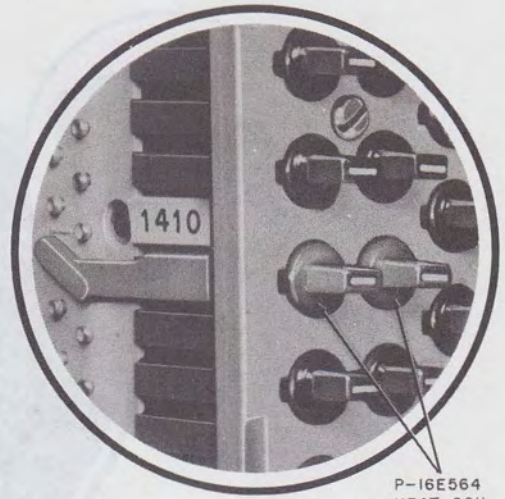

Fig. 34—Warning Marker Form E-5190 Installed on B Wire Marker



LIST 5



LIST 6

P-16E564
HEAT COIL
CAPS

Fig. 35—Installed KS-16576, List 5 and List 6 Designation Plates (MD) and P-16E564 Heat Coil Caps

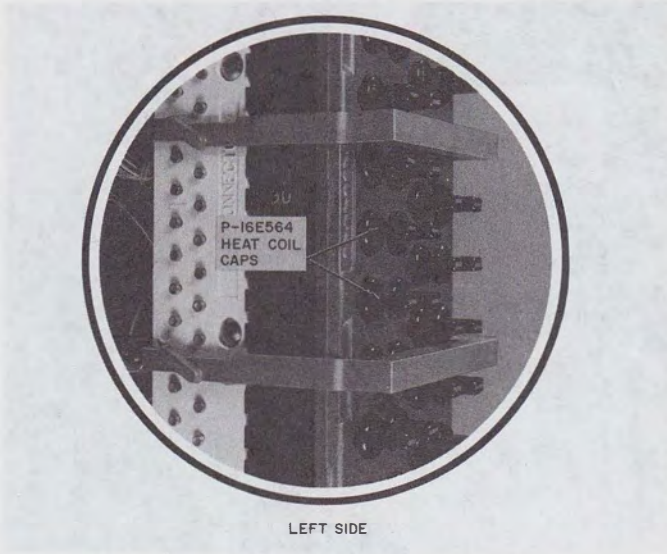

LEFT SIDE

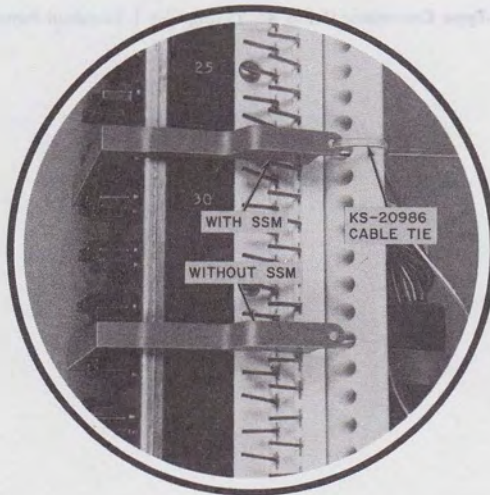

RIGHT SIDE

Fig. 36—KS-21369, List 1 Guard Installed With and Without SSM

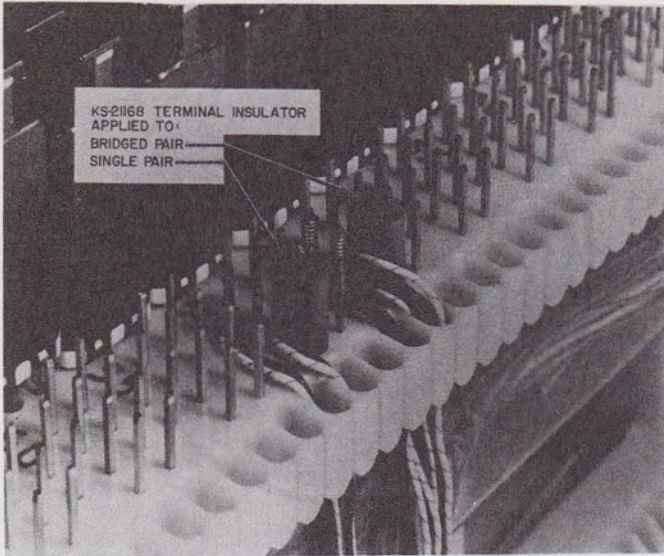

Fig. 37—SSP on 300-Type Connector Using KS-21168, List 1 Terminal Punching Insulator



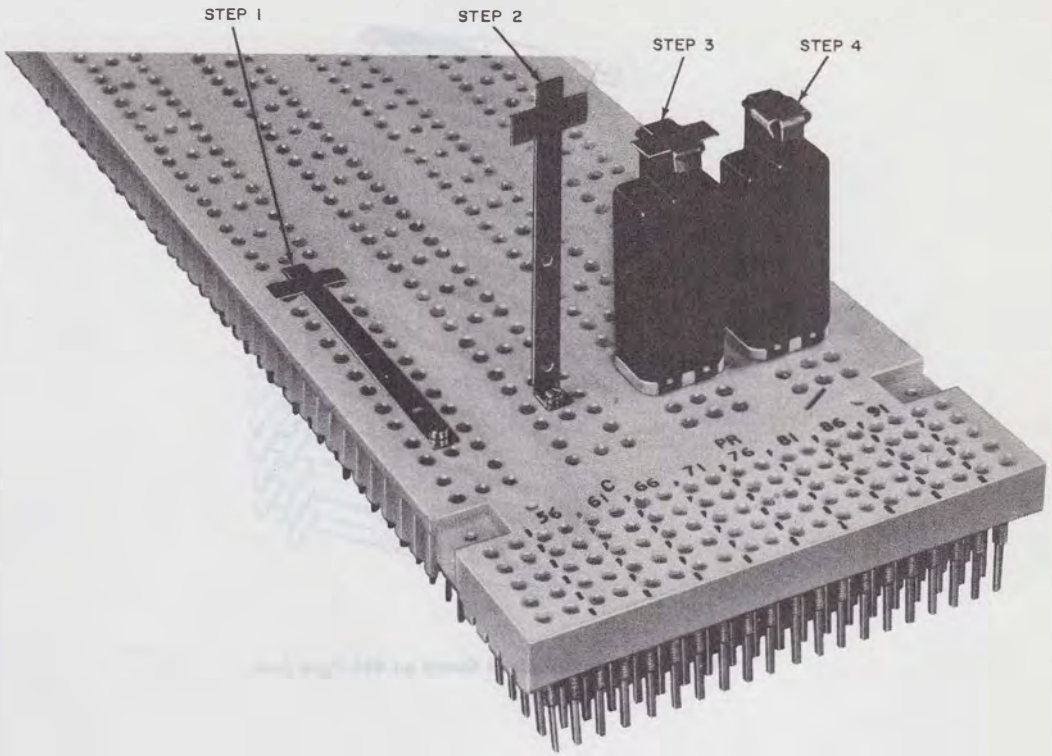

Fig. 38—Installing 20A Circuit Guard

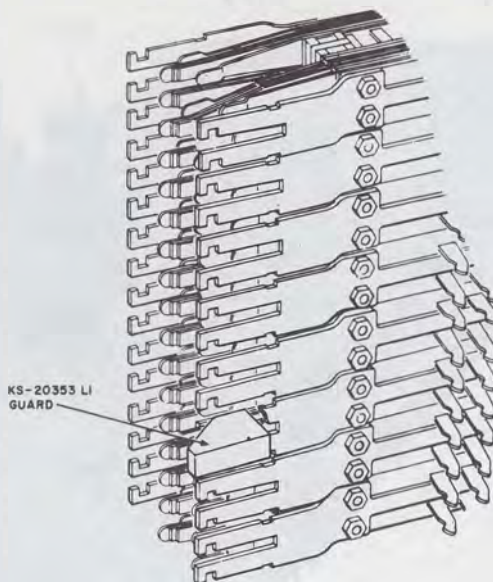

Fig. 39—KS-20353, List 1 Guard on 444-Type Jack